



the memory & poetics
of the place we call
HOME

Table of Contents

Preface:

9

Chapter 1 - Thinking:

22

Chapter 2 - Research:

70

Chapter 3 - Personal Research:

75

Chapter 4 - Notes:

82

Preface

For my Father Paul,
Mother Tammy
and Brother Paul

All my life, I thought extensively about the place I have lived in. It is very simple; a 1970's manufactured Quad, in a suburb of Sterling Heights. An odd place to be fond of. There is nothing about the architecture that makes it interesting, nor anything about the surrounding area that brings it any excitement. Usually the majority of people wouldn't take a second look at a house such as this. Passer buyers don't think about this area; do they?

I've always been curious about what people thought of this suburban area. Do they look at the houses, or the people? They may only think about the houses, because that is what they experience as they drive by. Clearly, the people and families who live in the area are quite familiar with it. They know every crack in the cement sidewalk, every Sycamore tree on the block. This evokes thoughts in my head; is there more to dwelling in areas as simple as these, or is the simplistic lifestyle all that life awards us with? The existence of small details, noticed while living in the same space.

Maybe these details evoke feelings of being comfortable, and familiar; these feelings must mean something. When we drive home from our previous destination, it's almost subconscious, since we have taken the same route hundreds of times. Did we even notice we drove thirty minutes home? Guaranteed, the one thing on the mind, is the sigh of relief of pulling into your driveway, and thinking "I'm home".



“Rushing every morning, continuing

this phenomenon, called routine

Unsure of the first name, or even the last,

as soon as the sun starts setting, I start my car,

the chaos for the day is seemingly so far.

There’s nowhere else in the world I feel that I belong.”

Growing up, I had two loving parents who were patient, and thoughtful, a younger brother whom I adored, and my cherished cat named Tiffany. My dad taught me all of my imagination, and meticulous skills, and my mom taught me about love, happiness and meaning towards things. I had a wonderful childhood growing up, but what I remembered most, was it was filled with imagination. Whether it was out in the backyard with my younger brother, in the basement, or in either of our rooms. My brother and I created a whole other universe of our own. I remember vividly, how excited I would be to go home after school, just so my brother and I could finish the story with our toys we had made up the day before. The stories were nothing short of simple, they were extremely complex, down to the smallest details of an instance. Curious, that such a big imagination was occurring inside such a simple house. These memories of childhood will always remain on my mind, solidified, as though they exist in a permanent file in my brain.

I still daydream about those days, being considerably older, and still living in the same house. I will sometimes pass by a space where we once played and I can in vision us sitting on the ground, laughing and focused on our miniature story I can even imagine what the room used to look like. It’s like an uncanny experience for me, that I could recall a space so vividly though it no longer exists. I know that one day, when I grow older once again, the memories my brother and I are making now, will flood my memory for the future.

“Here we sit, here we laugh, here we cry.

Here we work, here we think,

here we say good-bye

to all the memories gone before

These walls whispering as we leave,

Here is where it all began,

do not forget me, old friend

for I am always here

capturing all of the untold, that will be

stored away, inside ones soul.”



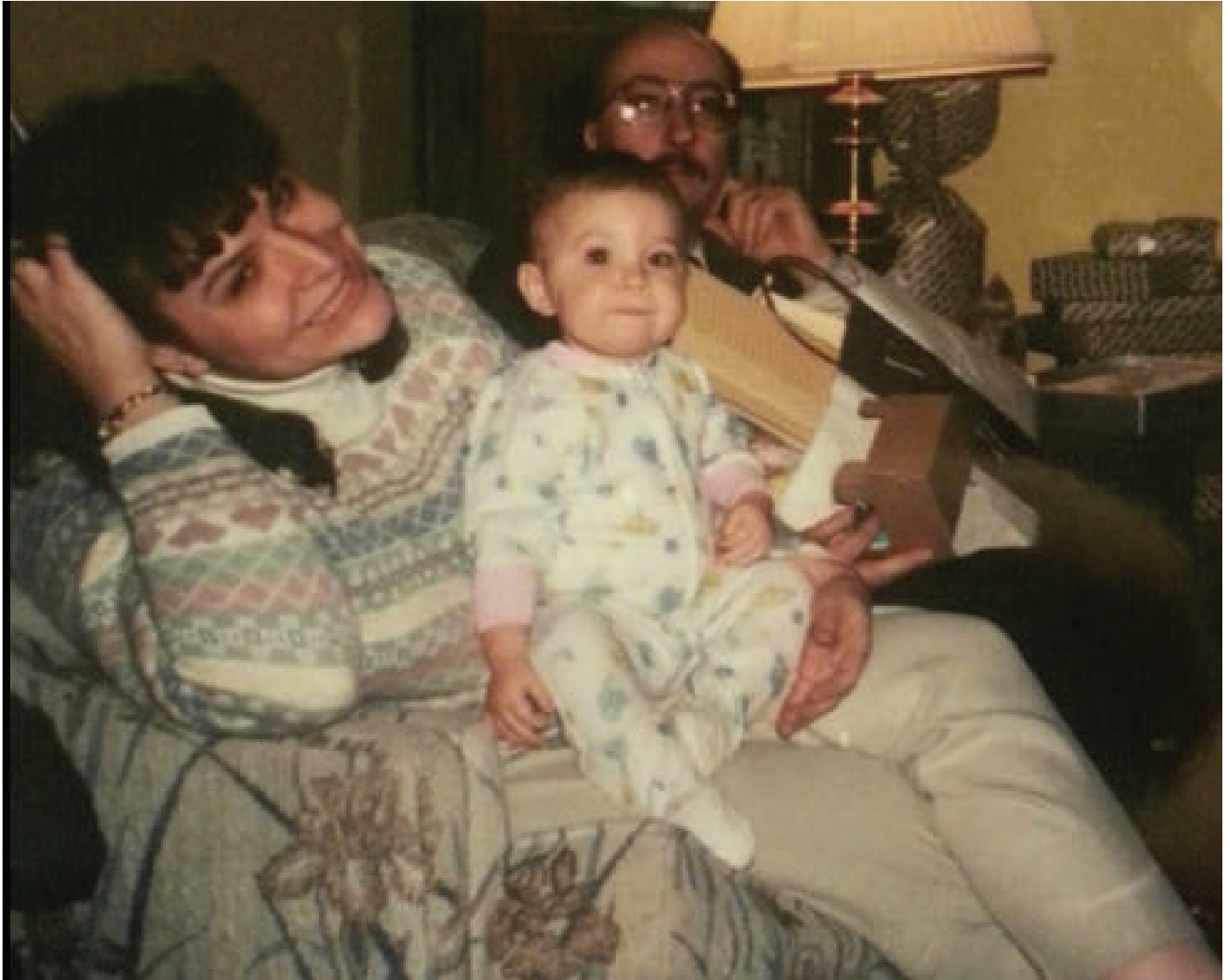



“the amount of imagination,
the amount of dreaming, the amount of
thought and time in one space
creates a house in your mind that is part of
the unreality that will forever be infinite”



there is personification of the house need to
represent
“houses that were lost forever continue to
live on in us; that they insist in us in order to
live again” (GB)



“Belonging, Wanting, Receiving.
could we belong to something and nothing
all at once or belong to nothing and
something not at all is that space we think
of truly ours or does it move”

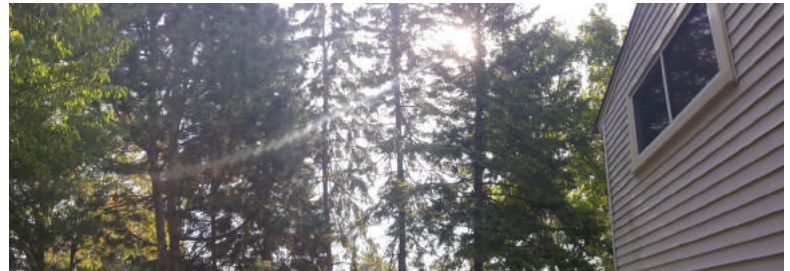



Thinking

Architecture.

The built environment has been around for centuries. It has evolved in different times, and spaces all over the world. In a way, it's an enigma. Architecture is the reflection of the changes in culture, and technology within a community of people; it's a space for existing, communicating and dwelling. In essence, architecture is the physical representation of a footprint, defining the history of a region. However, there is a part of architecture that is undefined, in another realm. Architecture is recognized on many different scales throughout the world, however there is a deeper meaning to architecture when you start to look at it through a refined lens. The domestic scale of architecture starts to speak of identity, and where a human dwells throughout their life. This reality of existing in a space, has a familiar energy that carries on with one's self forever. Not all architecture is considered a "house" or a "home". To a human, some built spaces are their own corner of the universe, it's what they know as they grow and evolve throughout time. The spaces speak for themselves in ways, unexplained.

This thesis is based on personal sentimental things, thus the preface. Through the years, conversations between people consisted of shared experiences, and stories. One theme throughout these conversations was about the homes they have lived in through the years, and the memories they have had in the spaces. Some people's memories are spread out to different homes while some have lived there their whole life. You start to notice different thoughts about the spaces depending on the individual. Some personify the spaces, and every where they walk, or turn, or sit, even just look. Memories are constantly flooding in one's mind.

. Others may only connect to one single room. Memories are part of the way stream of thought flows. The research started off with Memory. Memory is something all of us can understand and comprehend. Being aware that memory is occurring in the mind anytime one recognized something. An object, such as a figurine, or a style of house that resembled your own. Visually seeing these things triggered thoughts creating a memorable moment, or familiar feeling. When you start the process of researching anything, you start off with the basics; looking up relevant articles, and renting books. You tend to do a lot of reading. There would be small bits and pieces of information related to what one was aiming to study, but nothing was exactly what the research was begging for. The information gathered in the beginning that was useful to memory and spaces had to do with history of built spaces. People tend to recall memories with places they are familiar with, or in close proximity with. Spaces have a history of its own in the form of scars, embedded in the architecture. Seeing the scars left behind, can allow the viewer to imagine what the space may have looked like prior to reconstruction. For example, say there was a building that you know was once renovated. The upstairs level used to be filled with personal offices. Now that the offices are no longer there, the scars of the once existing walls leave a footprint on the floor. Those imprints is what remains of the office walls. People who used to work up in those rooms, now look fondly upon the space and remember the space for what it was. This train of thought is curious about the history of spaces, and the time stamp that the architecture left behind. During this thought process, of thought, one's mind starts to wonder. Is it the architecture that tells the story, or is it the human person?

Does the architecture create a physical presence reminding the person of the memory? Perhaps it is a combination of both parties, and you need one to inform the other. One other example of the architecture holding history embedded in its construction, was a conversation I had with my mother. I asked her:

“What if all of the furniture, paintings, curtains and carpet were removed from your bedroom. What would you remember about the room?”

She replied, “Nothing, I don’t think I would remember anything. There is nothing unique about the room that would stand out in my memory.”

As I was about to respond, she replied

“Although, in my grandmother’s house, she had arched doorways. That is something I will never forget. Memories about her house flow back to me immediately when I think about those arched doorways.”

This proved that the architecture does have something to do with the memory, in a historical, architectural, detail sense. My mother would never remember the simple, rectilinear doorway in her bedroom, or in the whole house for that matter. Perhaps uniqueness drives the memory. Maybe it’s the personal experience one has with architecture, and the mind picks some feature of the space to store away.



Those thoughts were important, however since this was as research process, experimenting with the findings was a next step. This process was inspired by the love of family, and a home dwelled in. It was time to dive into some experimentation to try and organize this way of thinking. The way some would organize theoretical thinking, is through eidetic imaging . Finding a starting point of how to tackle, or even comprehend, the process of memory within domestic space. One method used successfully in the past, dealt with layering imaging. The eidetic imaging is a tool to help understand what the potential of something is, or could be. The process is more complicated, but for this sake, eidetic imaging can shift or change a way of thought based on visual experience. Anytime there is a graphic experiment such as this, one's mind seems to become clearer in all the randomness of the process. I decided to explore another place that held deep memory; my late grandfathers cabin up north.

The cabin is also a simple style home. It is a Ranch style home, no basement. Off white siding, and mahogany spray painted gutters. There are too many memories here to even start talking about all the amazing experiences that were witnessed here. Even though the cabin looks like the most general house you can think of, a majority of memories were stored and celebrated on the interior of the space. The eidetic imaging started here. The eidetics were created from other images photographed in the past. The physical cabin was the main image, followed by images of daily activities, and past photos of my younger self with my brother.

The other images' setting was mainly outside. The property has a few acre land so when the cabin was visited in the summer, there would be plenty of yard work to complete. The manipulation of the images consisted of transparency, and contrast.

There was also some play with color to shift moods. These techniques allowed for an overlap of images, and the intensity of color, and delineation of space to be outlined. When the images were done and being analyzed, it was realized that both images strictly resembled the exterior of the space.

The interior is where most of the memories were documented through objects, however the brain continued to stop cold and not dive into the interior. Maybe diving into the interior was a vulnerable place. Perhaps it was the brain who had to go through the initial process of various imaging techniques to find this clue.

The images resembled the exterior space, was the image almost appeared flat; there was no further depth into the cabin space itself. The images represented an emotion, but no further investigation into the spatial quality, or philosophical view of memory. Curious, can memories only occur from the interior of a space?





The next step in the process was to try another graphic approach. Images were selected of both the interior and exterior of my home. This was done to change the perspective of perception. One was in direct proximity, instead of assuming perception of the cabin which wasn't in proximity at all. There were three images chosen and all three images contained part of the architectural structure in some way shape or form. The images chosen all had a type of memory connected with them. They were details of the home that stuck out in the memory.

The first image was an image taken facing up towards the red brick chimney, capturing part of the sky, and part of our twin walnut tree. The second image was taken facing downward toward the floor, on the interior of the house facing towards the Chinese Art Deco rug by the front door. The last image was a zoomed in image of wet, yellow flowers from the forsythia bush in the back yard. The off white shutters of the side of the house resides blurred in the background. These were placed side by side, and instead of creating an eidetic image, I started to extract detailed parts of each image, and rearrange them in a different composition. This skewed my perception of the spaces, even if one was experiencing them from a direct viewpoint. They were beautiful images to look at, but what did they represent?

Perhaps it was the fact that the perception of the space could be skewed in such a way, that the space could still be recollected by someone who recognized the image. Since the images were familiar, it was a chance to take another look at the cabin.

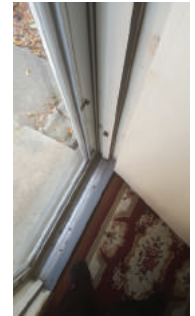
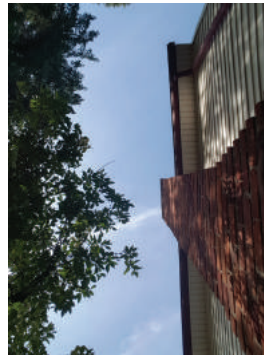



Two photos from the cabin space were extracted. One interior, and one exterior. The interior space was of the most used space in the home, the kitchen. The other was of the facade and important trees in the front yard. When these images were extracted, they read similar to the extracted images of the house's images. This graphic experiment with the extractions showed these images left room for unknown potentials of the spatial quality that the eidetic imaging didn't show. It was another layer of understanding of an imaging process that could also be used as a tool for learning in the future part of the process.

Graphic experiments continued because there wasn't a main literature text to drive the project as of yet. To sum up the findings thus far, sketching came in handy. The first series of sketches created, were tied to the idea of a person and a house. A person outside the home, a person inside the home, multiple people inside the home, then one person leaving the home. This small series had me continue to question the role of the home. Was a house the container for memories? Could other places contain memory the way a house did? When thoughts about where memories were generated, another thought occurred.

Maybe the time invested in a space leads to stronger memories attached to that space. This was a subjective train of thought, but this point had to be reached to move forward and strengthen the process.

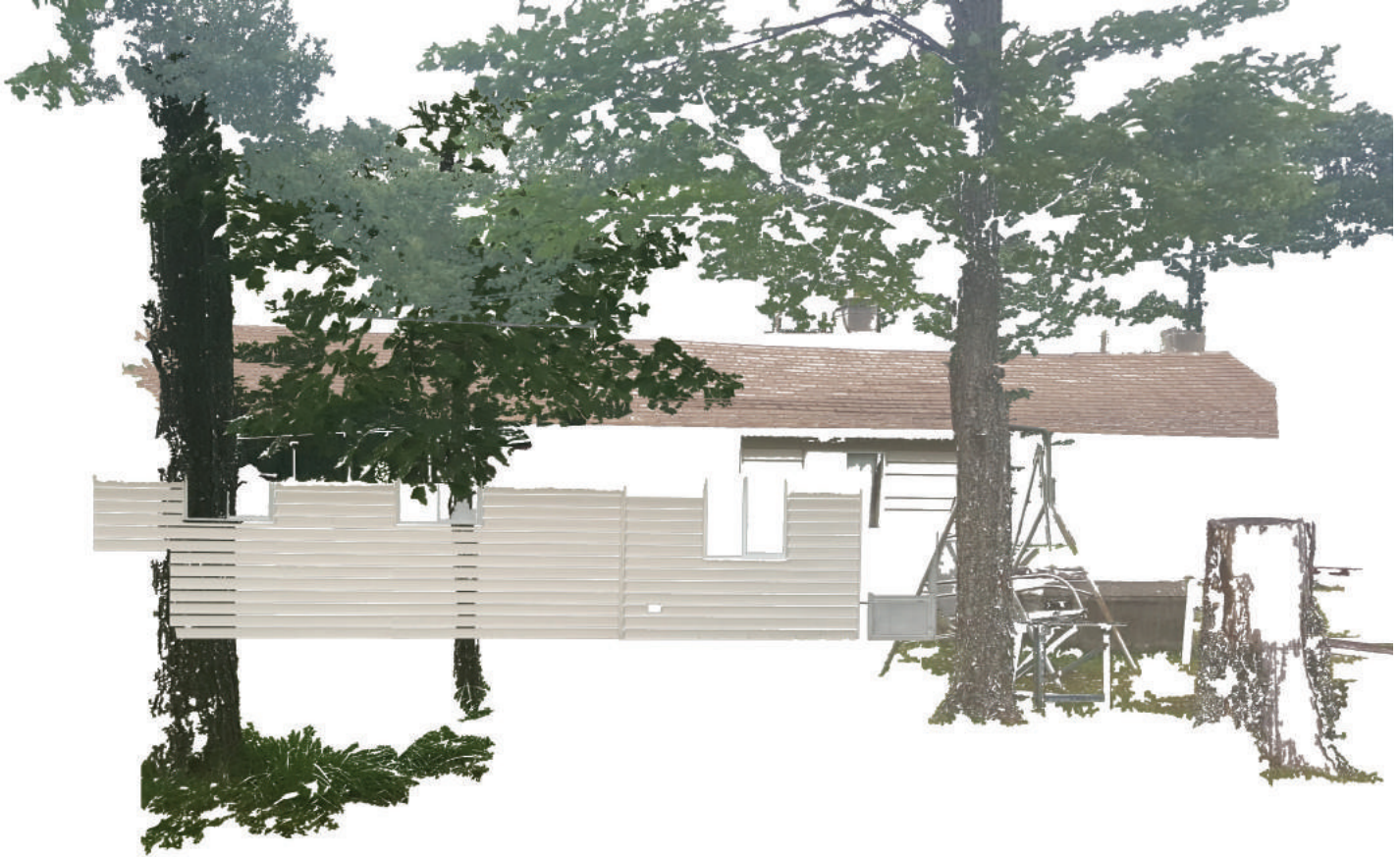
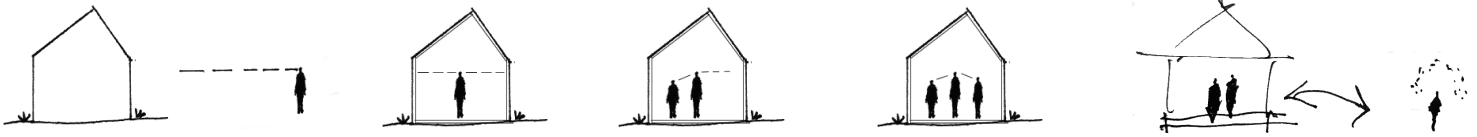

Once these thoughts started to develop, there was another series of sketches done. There was a short series of sketches representing the process of proximity to one's home and in proximity to different levels of experience. This idea of proximity came from previous thoughts within the extraction imaging process. The perception of a place based on the proximity to it. The levels of proximity included were: Personal, Collective, Communal, Public and Urban. Each of these conditions looked at the singular, to plural mindset of how to look at space. Are spaces meant for individual experience, or is there a plurality to experience? The way these concepts were represented was in a manner that started with a place. The image of the place started to grow with objects that were familiar to either one person, or many people.



Personal

Collective

The objects were somewhat defamiliarized, to add in the extraction concept utilized earlier. For example, the Personal example was my cabin. Each time the slide would change, there was a piece of furniture or texture added to the image. In a sense it was like an animation of recalling things that live in that space. The Public example was of The Roman Theater in Volterra, Italy. The objects being overlapped on The Roman Theater were familiar to more than just one person, and more than a group of people. The public would be able to objectively identify some of the objects, instead of the subjective personal experience of my cabin. This task of sketching the personal relationship to home, and a person's relationship to proximity allowed some personal conclusions to be arbitrarily drawn.

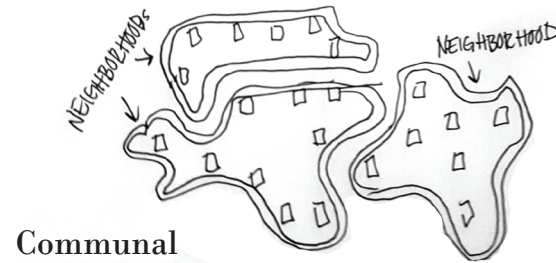

Communal



Public

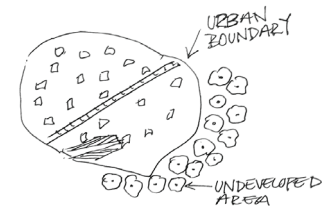

Urban

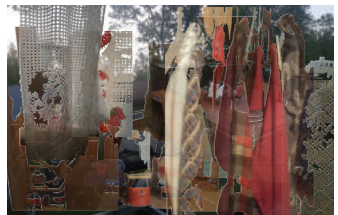
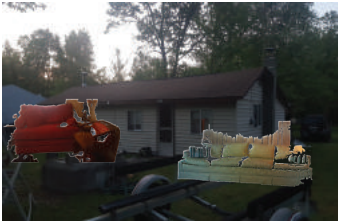

a. everyone has memories, it's how our brain gives time meaning.

b. memories take place, after an event happens.

c. to recall the memory once again, you must be reminded by the physical

d. physical space or objects live throughout time, in the past, present, unknown future.

e. memories therefore are rooted in the past

f. is the past, the essence of memory

These opinions have some validity to them in a learning process type way, however the literature later in the process will help iron these thoughts out more thoroughly.

This first segment of process was a lot of thinking, and experimenting. There are many ideas generated in the first segment and will be essential in the process and research to come. Without this experimenting and thinking, there is no basis for any real research.

Research

This thesis really begins with a text by Gaston Bachelard. This book helps guide the flow of the research more clearly, instead of having a myriad of random streams of thought. Bachelard was a French scientist, and later a philosopher. He wrote a book titled *Poetics of Space*. The text talks about the domestic space in a phenomenological sense. Therefore, it is a theoretical approach to architectural space. Bachelard has an in depth analysis of the role of a domestic house, or home in humans life.

He arbitrarily describes the connection between a person, and their place of dwelling throughout life. He describes sentiment, belonging, and existential emotions in the form of poetry. Since his analysis is based around words and poetry, and was helpful for backing up the validity of this thesis. Words are important for study, and important for expression. In a way, they allow for the mind to organize and gather information for further exploration of something.

Words can be documented, to show mistakes or successes of the past, or even anticipate the future. In this case, the words are used in a way to portray emotion, or more so, communication of feelings to one's self. Bachelard views architectural space, especially more personalized space, with this poetic lens. Bachelard's text has ten sections, but there were a few sections focused on for this thesis. The sections were, House and Universe, Shells, Miniature, Intimate Immensity, and *The Phenomenology of Roundness*. Each of these sections or chapters are detailed extensively, but there were important things learned in each to spark the next idea.

During this process of understanding, and studying *Poetics of Space*, there were iterations of drawings through the learning process to represent these theories. Mind you, the drawings were not directly related to each theory, they were an investigation of the theory. This thesis isn't meant to emulate the text, its meant to study it, use it as a resource, and in a sense challenge it from a new perspective. Though memory is a big portion of the thesis, Bachelard doesn't necessarily refer to memory, as "memory". He refers to it as "daydream". This will be further discussed later, however that is how memory is implemented into the thesis still.

After a level of understanding of *Poetics of Space* was comprehended, there needed to be an objective experiment to test the theories, or at least get something started for a further investigation into the theories discussed. Interviews were assessed in two suburbs which were Sterling Heights Suburb, and a Roseville Suburb. There the interviews were documented of twelve residential homes split between these two cities. To keep the house style of home consistent, only three types of homes were interviewed; Colonials, Quads, and Ranches. The interviews consisted of questions about culture, occupancy, and the room where the most memories occurred collectively. The interviews were in person. Having the interviews in person was helpful to experience the space the interviewee was talking about. The interviews were simple, and straight forward. The only request that may have been perceived odd was the interviewer asked for a photo of the room with the most memory. There couldn't be any people in it either, it would defeat the purpose of the task. I thought about it as a portal; that this image was a representation of what the people living there saw with their own eyes.

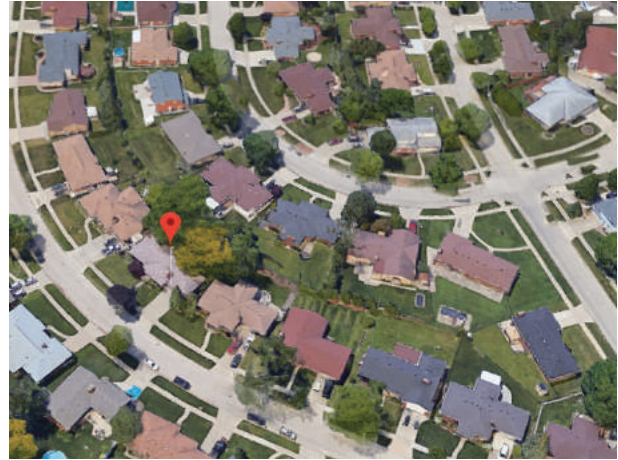
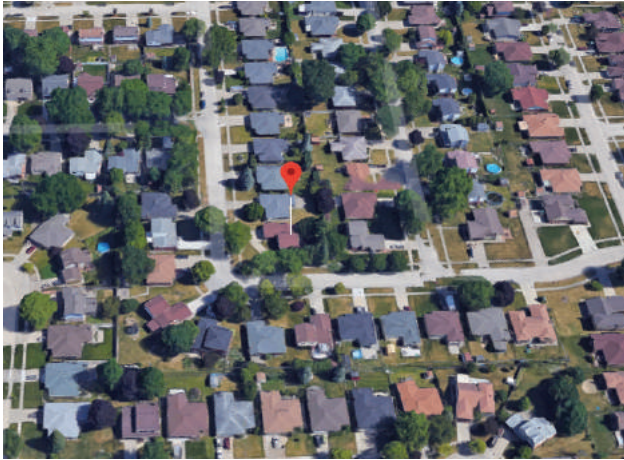

Sterling Heights Neighborhood Rooms



Garage

- 4 People inhabit
- Bosnian Culture
- Strongest memories in Garage
- Quad Style Home



Dinning Room

- 3 People inhabit
- American Culture
- Strongest memories in Dinning Room
- Colonial Style Home



Family Room

- 6 People inhabit
- American Culture
- Strongest memories in Family Room
- Quad Style Home



Family Room

- 2 People inhabit
- American Culture
- Strongest memories in Family Room
- Quad Style Home



Family Room

- 4 People inhabit
- American Culture
- Strongest memories in Family Room
- Quad Style Home



Living Room

- 4 People inhabit
- Polish Culture
- Strongest memories in Living Room
- Quad Style Home

Roseville Neighborhood Rooms



Kitchen

- 5 People inhabit
- Albanian Culture
- Strongest memories in Kitchen
- Ranch Style Home



Kitchen

- 3 People inhabit
- American Culture
- Strongest memories in Kitchen
- Ranch Style Home



Dinning Room

- 2 People inhabit
- Italian Culture
- Strongest memories in Dinning Room
- Ranch Style Home



Dinning Room

- 1 Person inhabit
- Italian Culture
- Strongest memories in Dinning Room
- Ranch Style Home



Family Room

- 4 People inhabit
- American Culture
- Strongest memories in Family
- Ranch Style Home



Kitchen

- 4 People inhabit
- American Culture
- Strongest memories in Kitchen
- Ranch Style Home







The main task was to try and learn about the space itself, not learn about the people inhabiting the space. Learning about the culture of the people living there, was another layer added to see if there was any relation, or connection to the memory of the spaces in the specific home among other cultural backgrounds. After the interviews, the next part of the process was to examine the interior and exterior built space itself.

The interview was a success, but turning it into something tangible to study was another animal. The rooms were independent from one another, and separate from their exterior. To start examining the built space, along with the individual rooms, there was a series of drawings done. The drawings were of the exterior front facade of each of the homes interviewed. Then, a drawing of the room overlaid on its house it belonged to. The colors from the original photographs of the rooms were implemented in the drawing, to try and grab some essence of the room itself. It was almost as if the drawings were giving new meaning to the types of homes. The facade of the homes drawn remained black and white to emphasize the room. At first glance, all the homes in the original photographs have one type of language, and are interpreted quite literally, and equally. However, once they were drawn, there was a new language created. It celebrated the homes with a new sense of experience, with individual quirks, details and all. This was the breakthrough in the process. The drawings of the homes represented something that was more than just the face value of the building. The intention mentioned earlier of overlaying the personally chosen room, was to have that visual of what the person might view when they look at their home.

. Another reason is so that the experience is placed in an objective realm of meaning. Physically, if any person looked at the room, and looked at the room's image, they would see the same thing.

There were some eidetic images also created to try and learn something about the neighborhoods that were being studied. The one thing about these eidetics, was color was very present. In another study of these interviews, color will be implemented.

Not only the eidetic images, but there were also some models created to try and understand space. They were called "memory rooms".





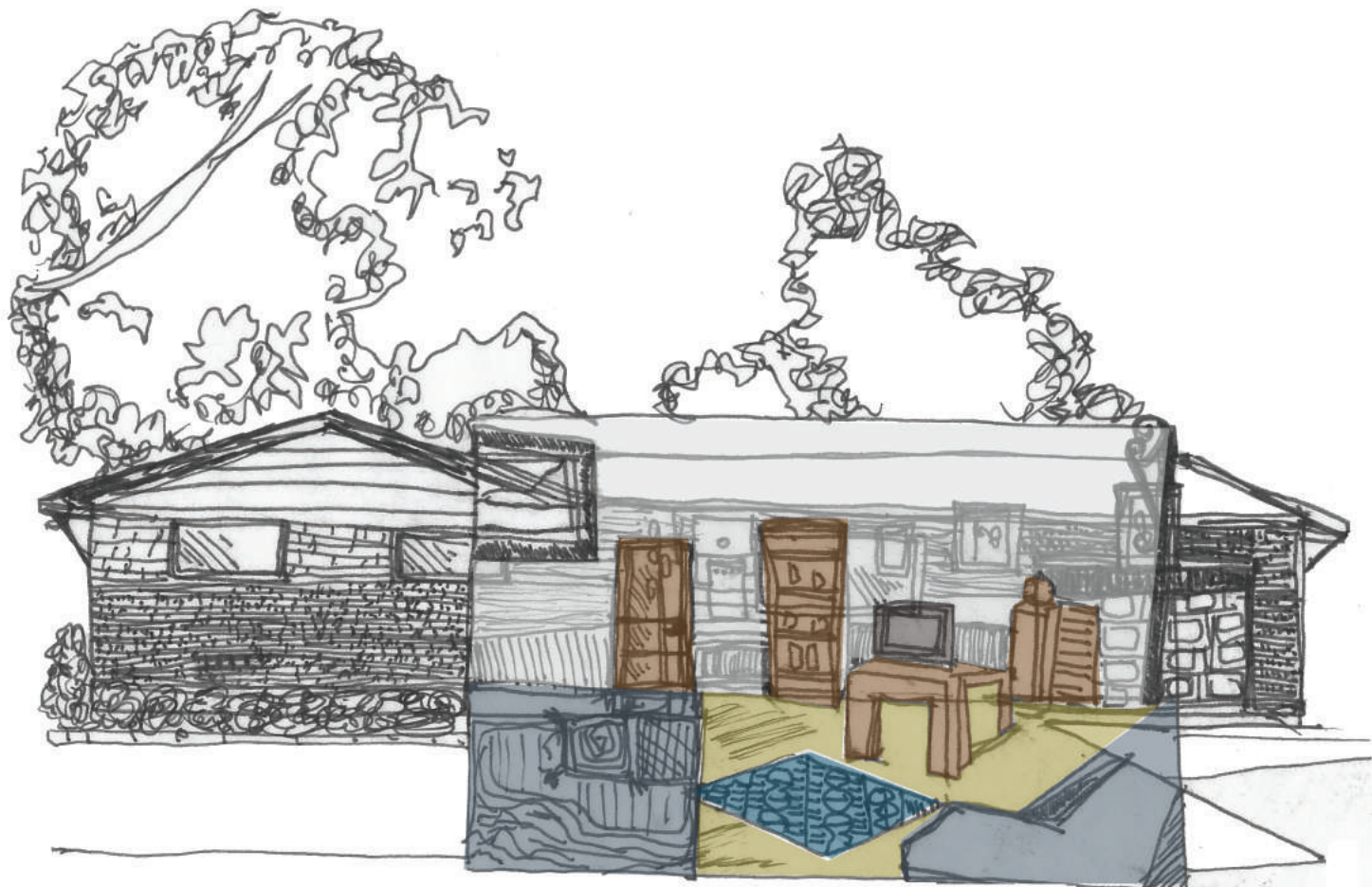

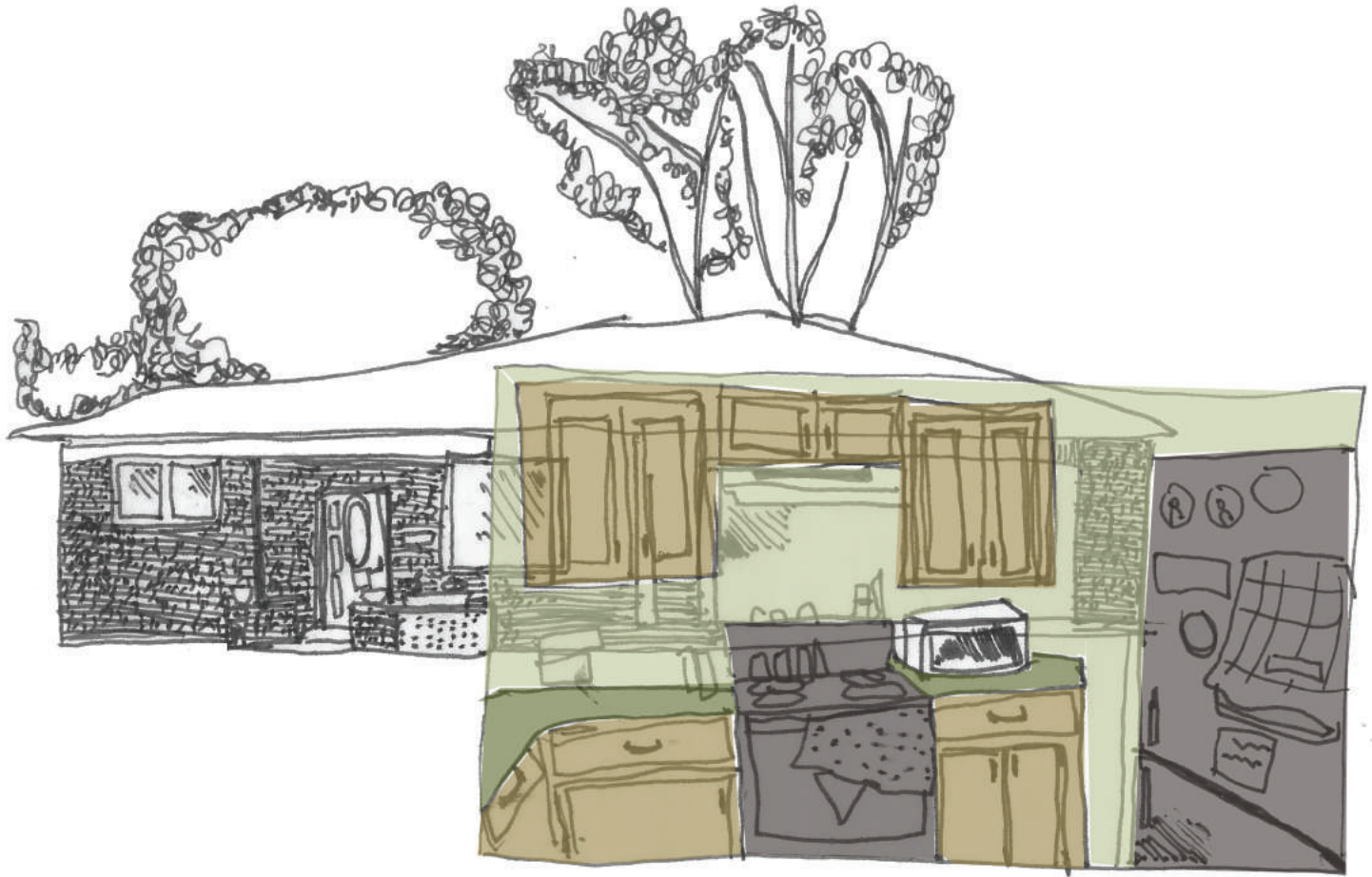

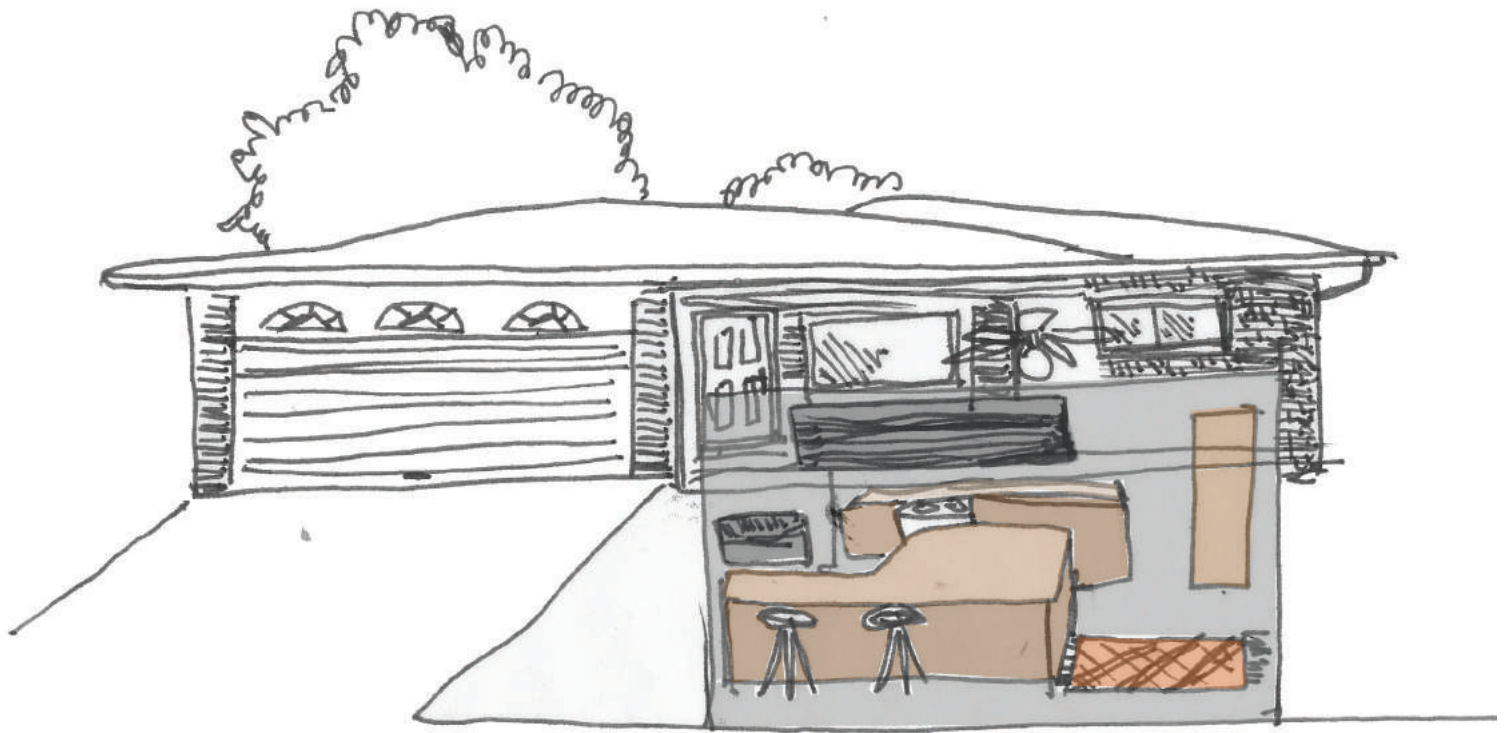

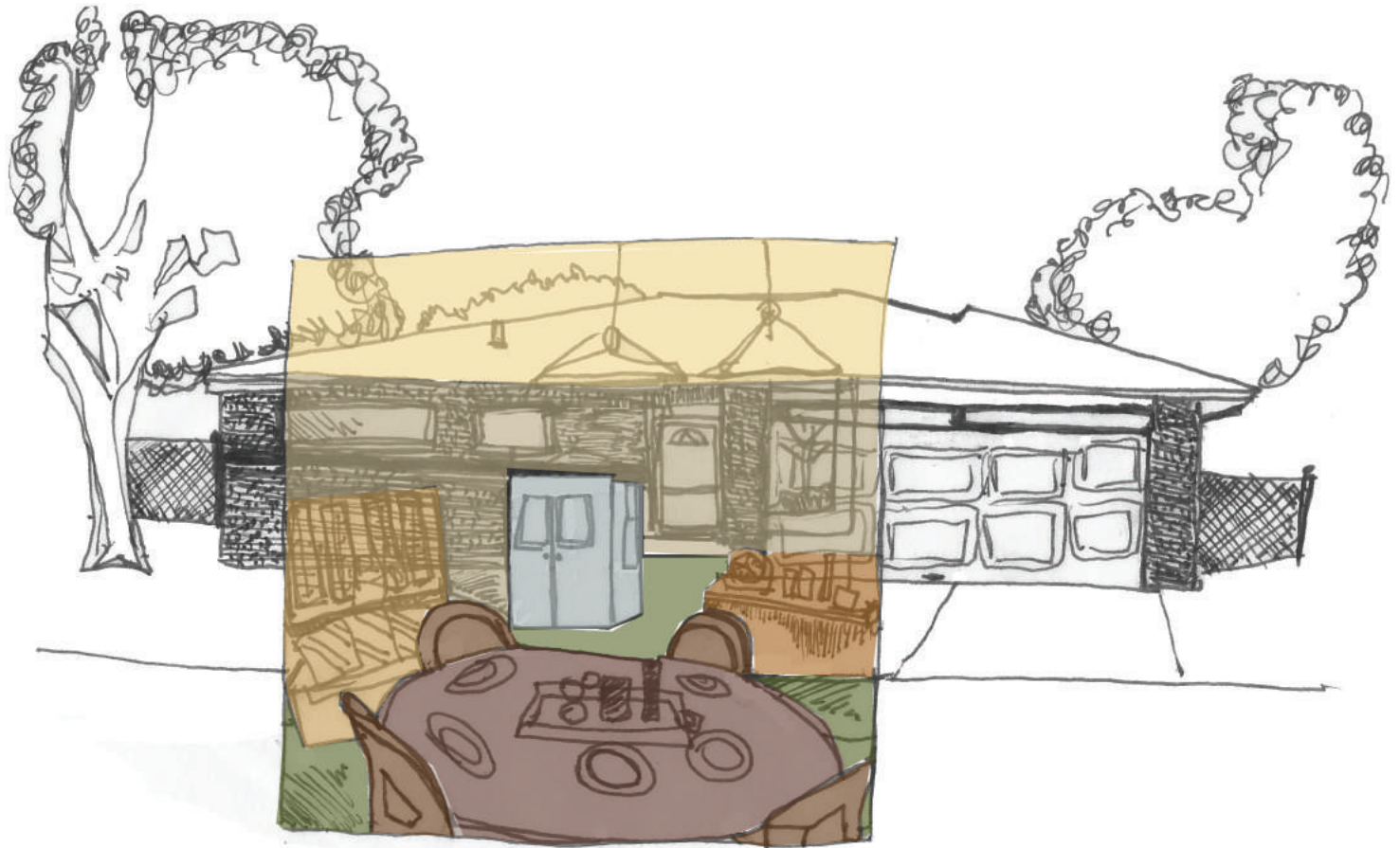





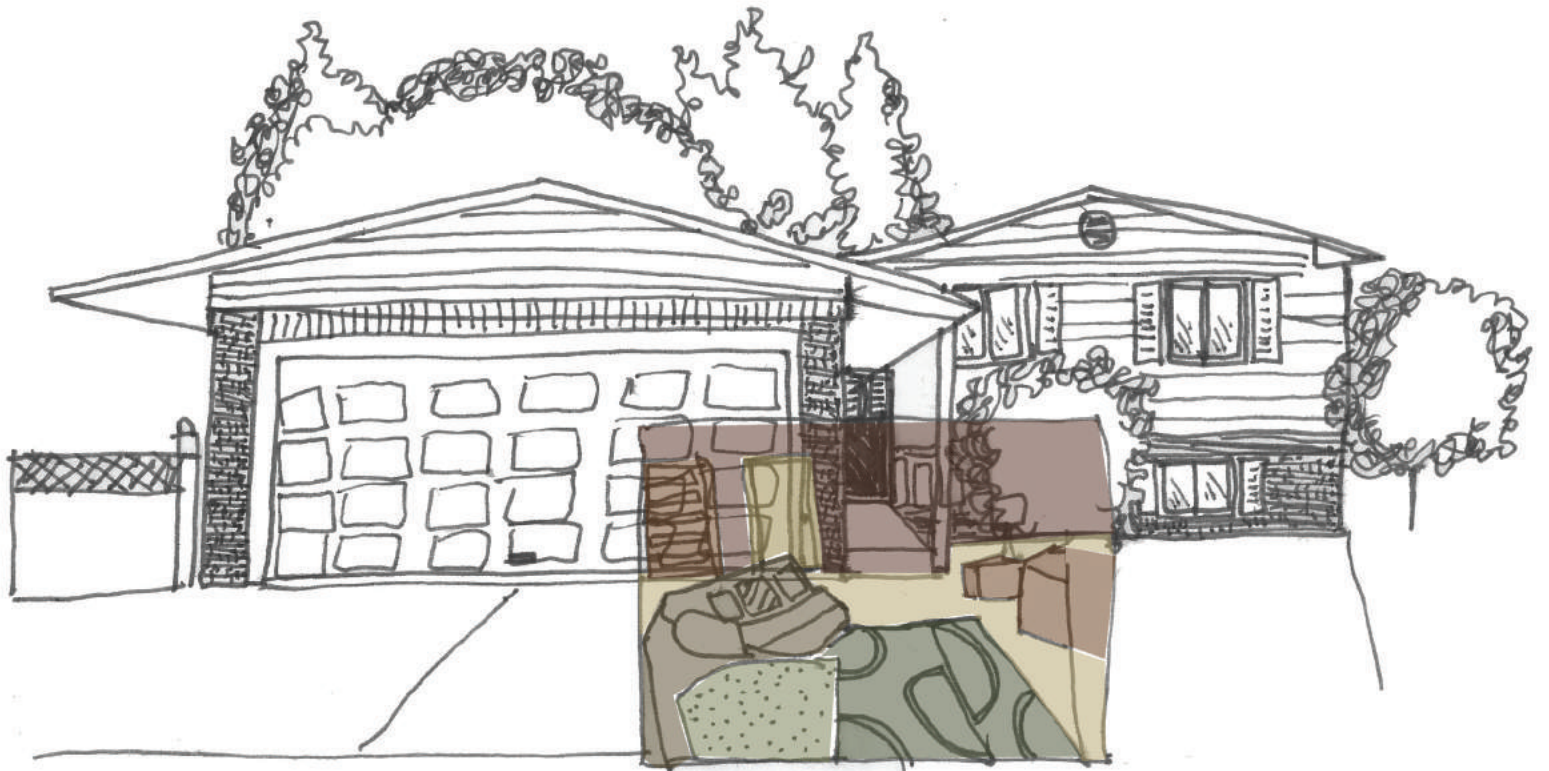



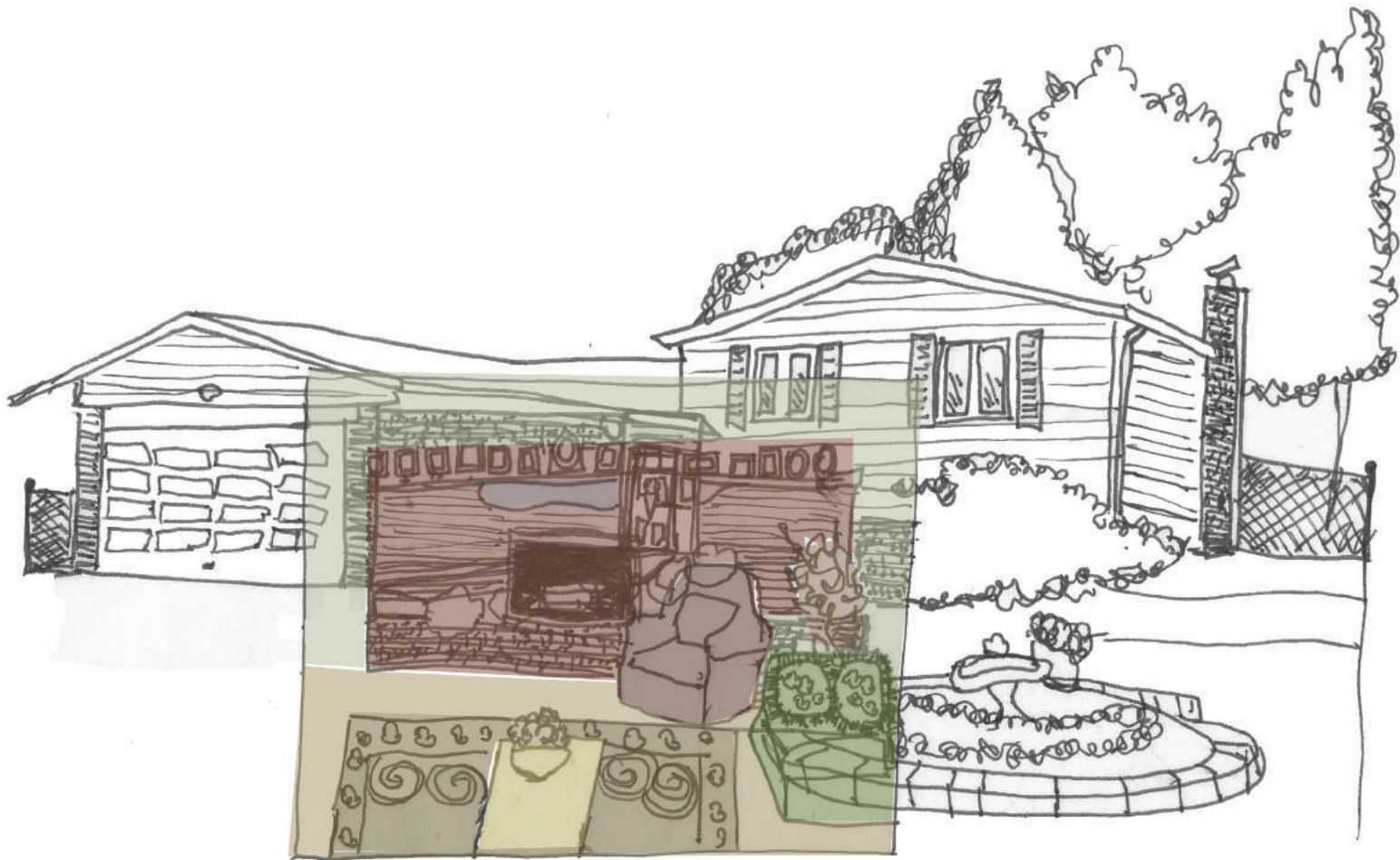



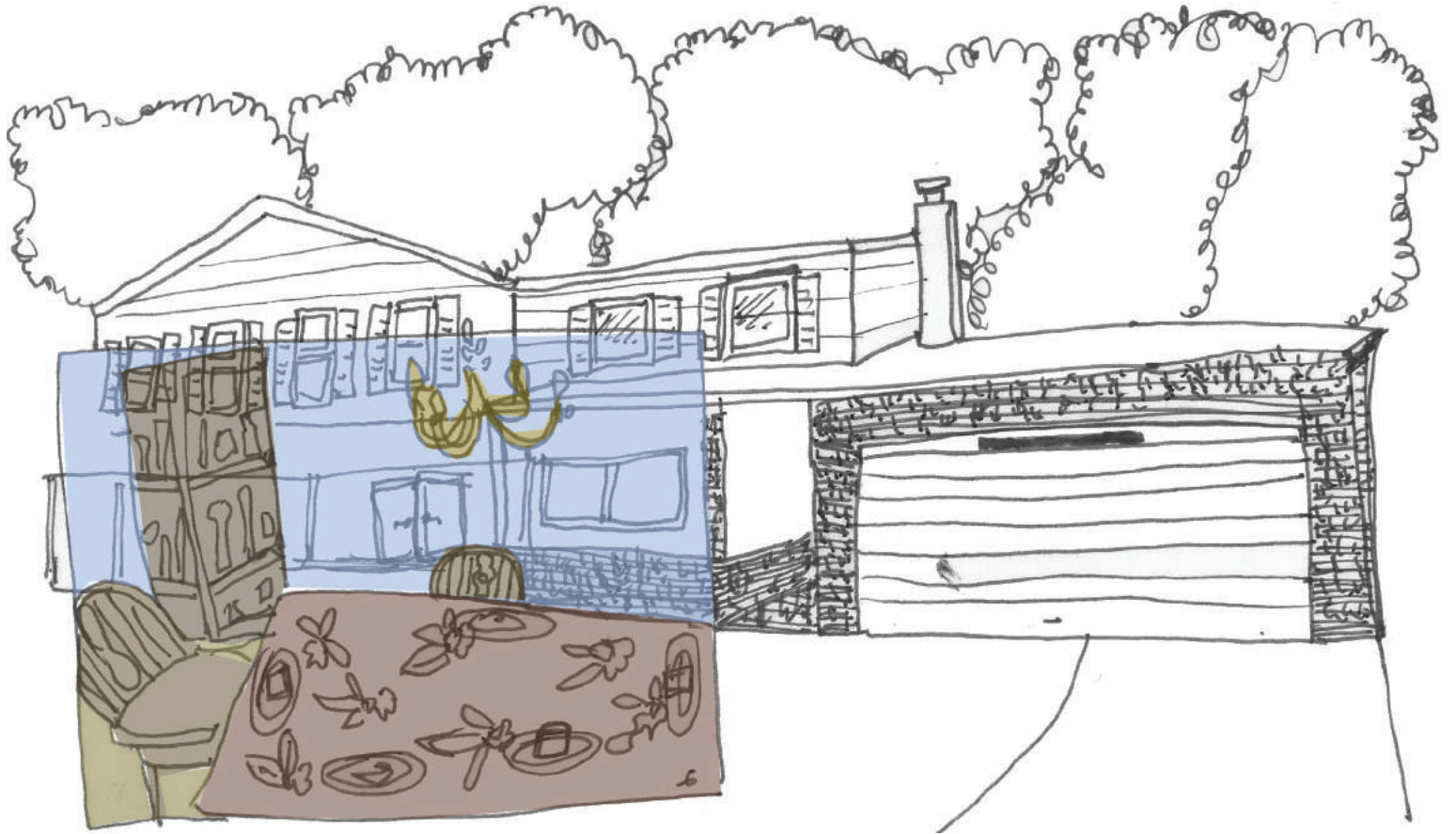



Miniature:
a detail, noise, vision of an object;
“obstruction of vision and focus, that magnifies habits,
daily
routines, all housed within the mind.” -Emily Pace



After the first iteration of drawings, the next step was to dive back into research. Mentioned in the beginning of the chapter, Gaston Bachelard had a myriad of theories that related to the thesis. Now, onto the theory that went behind creating these first set of drawings. Bachelard talks about the theory of Shell. Shells are essentially the building itself. It encapsulates anything on the interior, without movement. It stands still, and serves its purpose in a humble manner. The built space is a hollow entity, standing tall, waiting for an inhabitant to choose it. In the drawings, the exterior of the building was meant to represent the shell that would always remain its simple, stagnant existence.

The overlaid room, represents Bachelard's theory of Roundness. The theory of roundness may be a bit difficult to describe. Imagine a sphere. Imagine, the sphere is spinning, in a rapid motion. While you are thinking of that mental image, think of your brain simultaneously. All of the neurons firing, and energies being transferred in an infinite cycle. For a better example, think of ants building an ant hill, and their endless mission to place each grain of sand on the pile. Imagine a space, with a spinning, neuron-firing, ant delivery cycle, going on infinitely forever. The description is a physical representation of the theory of roundness. There is infinite potential for every architectural space in a building, in a swirling, supernatural sense. However, the roundness mainly refers to the home, according to Bachelard. The roundness theory is stronger within the home, because there is more freedom to be one's self. The theory is based around one's thoughts, and one's potential of any kind.

The objects in the overlaid room photo, represent the theory of Miniature. Miniature relates directly with meaning. There are things in our everyday life that we are familiar with. Our favorite pan in the kitchen, a vase your mother got you, your old toys from childhood, the list could go on. Miniature are the objects that we surround ourselves with in everyday life. We base our life around what we have in our direct experience.

These objects are menial in the grand scheme of life, but humans personify, and give meaning to things that have helped them make everyday life easier to live. Bachelard looks at miniatures as a magnification of reality. Humans often refuse to look outside themselves, and choose to dive deeper into things that don't have a lot of meaning. This could be because relating to these objects of direct experience is comfortable, and comprehensible. The objects in the overlaid room drawing represent this Miniature way of life. Going along with this idea of Miniature, There were miniature dioramas created to represent this theory.

Looking into these theories, and understanding them was a positive move for this thesis. However, diving too far into the theories may have put poetry on the back burner. Poetry. Such a mysterious thing. Poetry is always meant to make sense, but it doesn't always make sense. Bachelard's implementation of poetry into the text is strikingly beautiful. It is almost incomprehensible how he threads the words, emotions and fleeting mental images all into a few words. He refers to a few poets, who have a profound sense of awareness about knowledge and life. Though Bachelard speaks in this poetic tone throughout the book, how does the home respond to the poetry?

Thinking about the theories implemented into the other drawing study, there was now a base for the next drawing iteration. Bachelard talks about how poetry is a physical form of emotion. Maybe, poetry is what a space is filled with. In a virtual realm, the space is filled with words. Words, thoughts, conversations. Perhaps it is the space's job as that shell to be a container for the words. Perhaps the space speaks through the things you place into it, to make it personal, to make it intimate.

Every piece, color, object, texture gives life to a space, those objects, patterns or details represent the words that are not being said. Unspoken questions and conversations that are waiting to be heard about. The virtual conversations that occur in each of our minds has an individual quality that is celebrated with the physicalness of the world; the physicalness of each thing in a room. The words are in the details. However it takes a human to uncover these hidden unspoken words. Once all of these thoughts were realized, the next iteration of drawings was in order. Similar to last series of drawings, there would be parts of the exterior shell of the home, and the room overlaid would be more abstracted as well.

The words recorded from the interviews, and with some personal interpretation, words would be hand written in a linear fashion, following the lines of the drawing. The words would also fill in small spaces of the house drawing to give hierarchy. There would be six drawings in this series and all drawings would remain black and white, so the free hand writing would stand out against the straight edges.

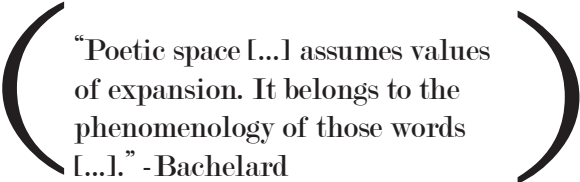

“Poetic space [...] assumes values of expansion. It belongs to the phenomenology of those words [...].” - Bachelard

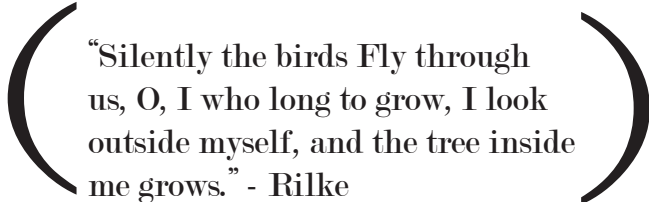

“Silently the birds Fly through us, O, I who long to grow, I look outside myself, and the tree inside me grows.” - Rilke

IF WE TRY TO SEE THE END, WHERE IS THE BEGINNING?
MAYBE SOME OF THE WORDS ARE HAUNTED

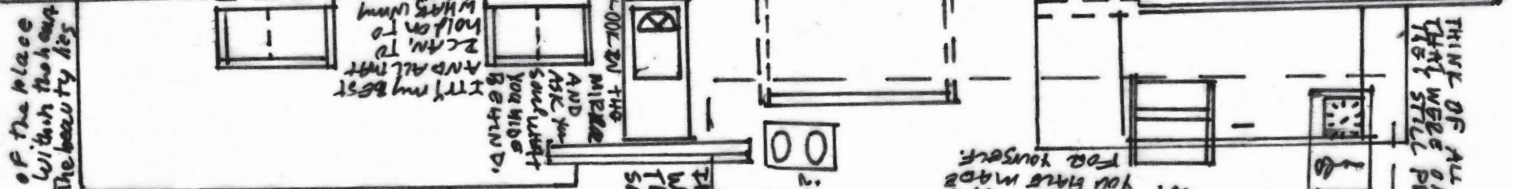

of the place
within that one
The beauty lies

TRY MY BEST
AND ALL THAT
SCAN TO
HOLD ON TO
MAYBE
LOOK IN THE
MIRROR
ADD THE
ASK YOU
SAY WHAT
YOU WISE
BEHIND

There are many memories made where
most dont even get to discover. Every
person is able to find their own memory

THESE MEMORIES
LINGER THROUGH
THE WALLS, AND THE
MY HAIR, AND THE
FLOOR - BOUNCING
ALL AROUND TRYING
TO ESCAPE.

IN ORDER TO UNDERSTAND
WE MUST FIRST SEE
THEN EXPERIENCE
SOMETHING WE DONT
UNDERSTAND.

AS I SEE
IN MY
EYES
I CAN
SEE
WHAT
I AM
DOING
AND
I CAN
SEE
WHAT
I AM
DOING



AT THIS TABLE
I SEE THE LIP
FOR YOURSELF
YOU HAVE MADE



THE WORDS OR VALIDATION WE SEEK
IS RIGHT WHERE IT WAS ALL ALONG

THINK OF ALL THE MEMORIES
THAT WERE ONCE HERE, ARE
THEY STILL PRESENT, OR PAST?

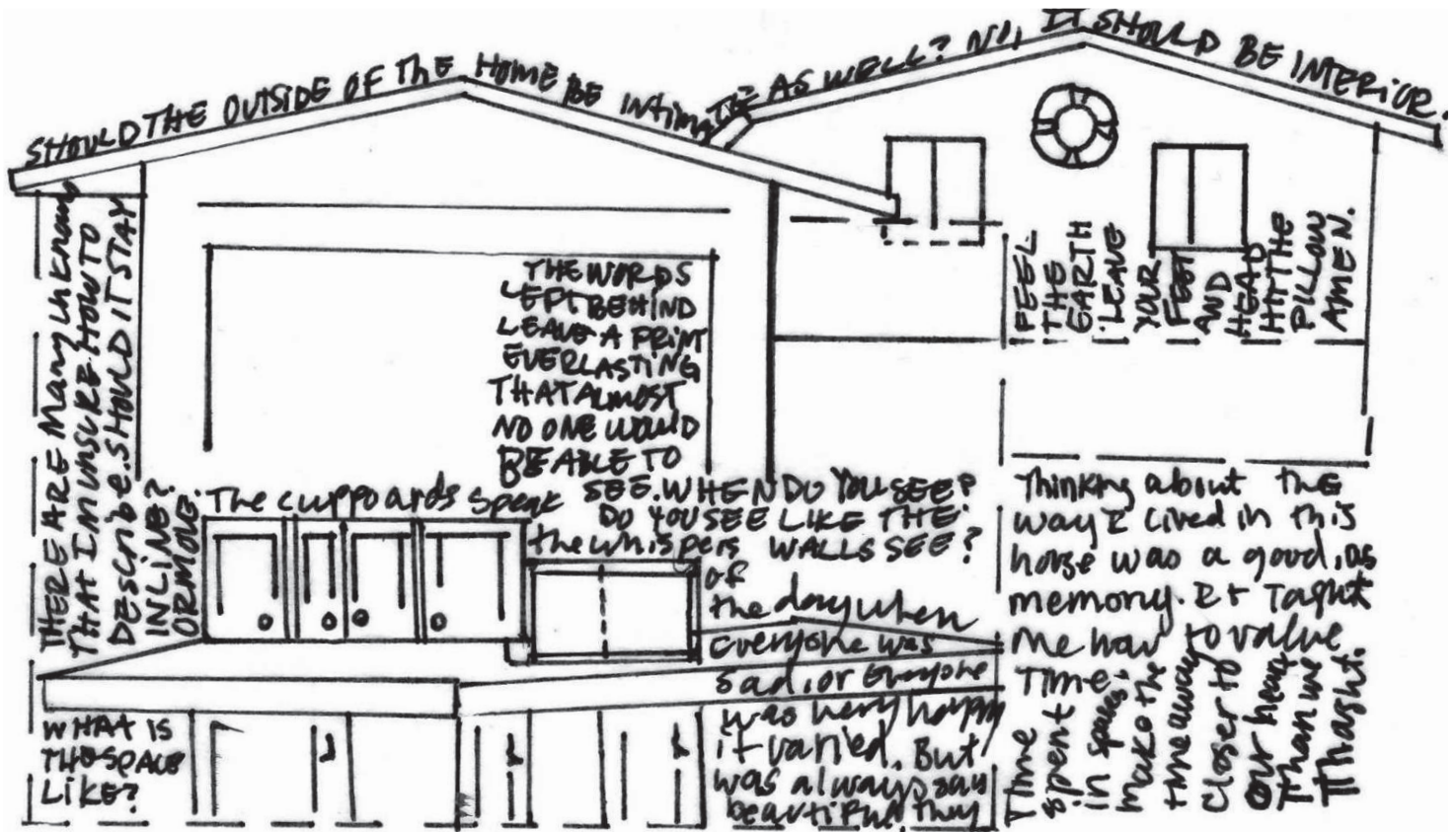



THE SENSE OF SILENCE IN A SPACE LETS THE
LIFE PART OF IT SET IN MORE HEVILY
THEN IT WAS THOUGHT OF THING.

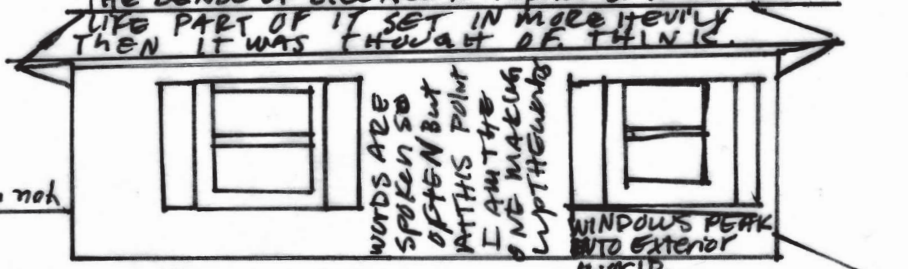

WORDS ARE
SPOKEN SO
OFTEN BUT
AT THIS POINT
I AM THE
ONE MAKING
UP THE WORDS

WINDOWS PEAK
INTO EXTERIOR
WORLD.

you need to try to think about what
THE IRRREGULARITY OF EACH SPACE IS WHAT MAKES
IT WHAT IT IS, OR WHAT ITS NOT.

many things are over

THE WAY
THAT THE
INTERIOR
SPACE SPEAKS
TO THE HUMAN
THAT LIVES
IN IT
GOING THROUGH
THE DAILY
ROUTINE

THE WORDS LIVE THE HOME
TELL THE STORY OF WHAT IS

WORKING
CLEANING
THESE WORDS
BLEED THROUGH
THE WALLS

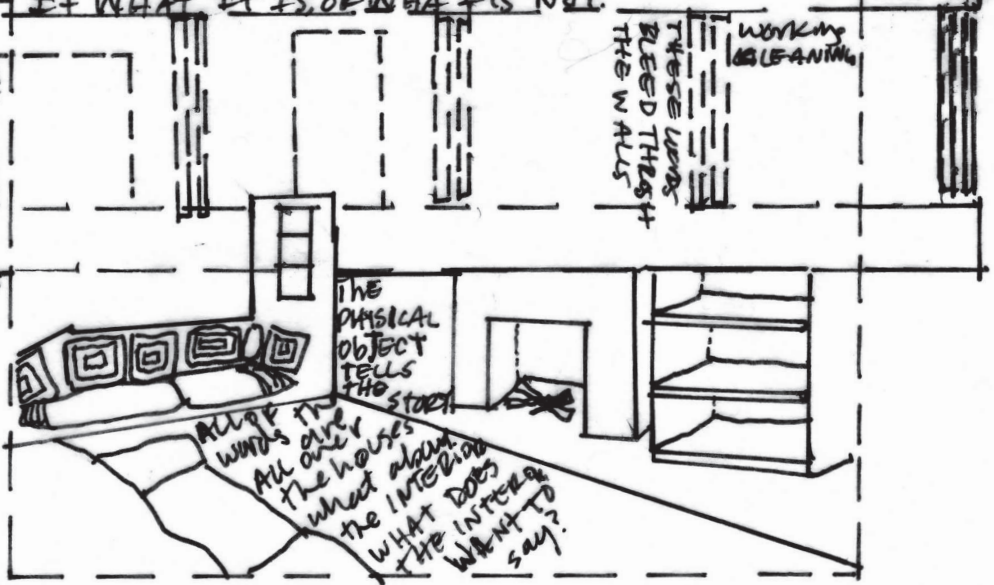

THE
PHYSICAL
OBJECT
TELLS
THE
STORY

ALL OF
WORDS IN
ALL OF THE
HOUSES
WHAT ABOUT
THE INTERIOR
WHAT DOES
THE INTERIOR
WANT TO
SAY?

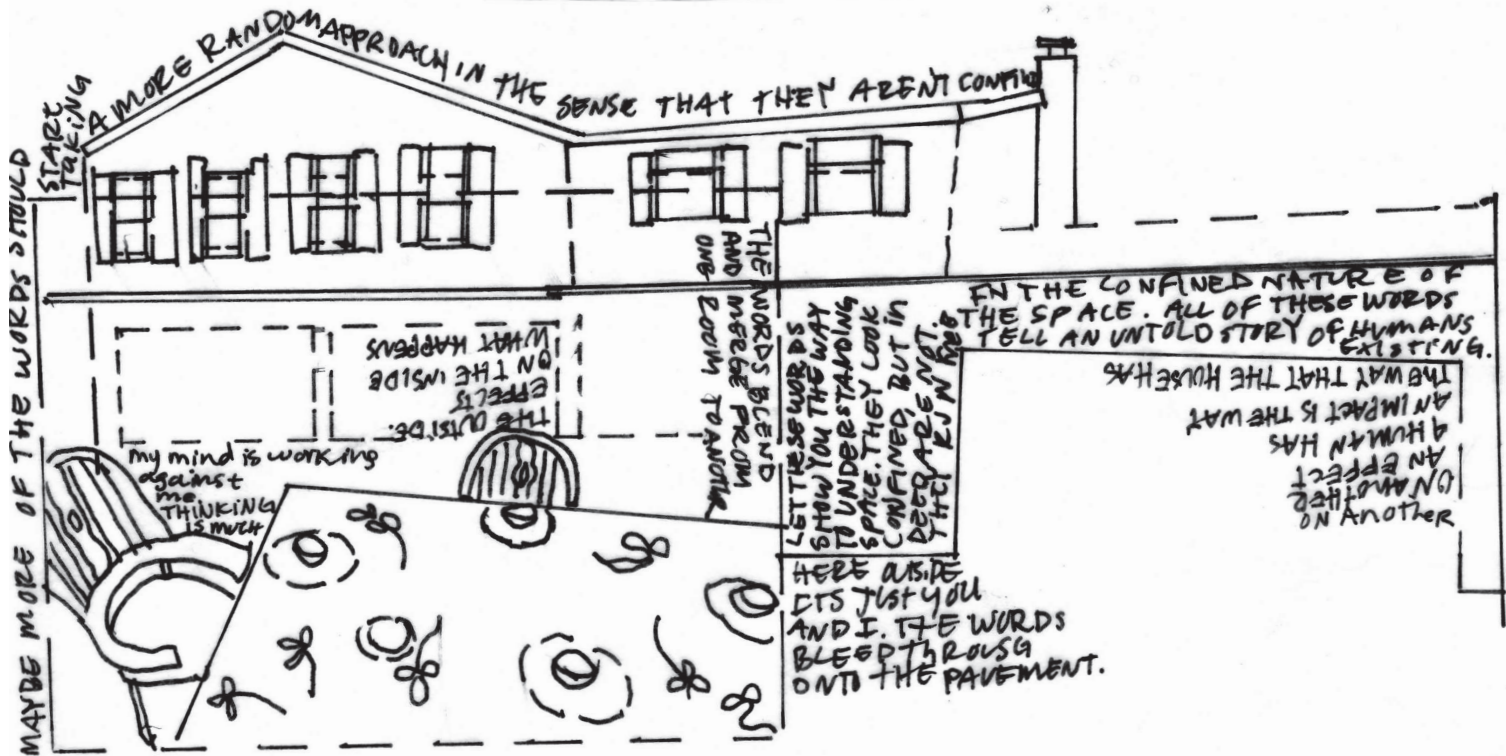

WAKING LIFE CANNOT BE RECORDED AS DREAMS CANNOT BE RECORDED. OR CAN THEY? IS IT THE SAME EXPERIENCE?



THE
OUTSIDE
EXPERIENCE
IS A
COMPLETE
DIFFERENT
ANIMATE
SIMILARLY
THOUGH
IT CAN
BE FAMILIAR

THE INTERIOR'S
OF THE SPACE IS
WHERE THE
IMAGINES ARE
CREATED. THEY
ARE RECALLED
THROUGH THE
PHYSICAL OBJECT
SPARKING IN THE
BRAIN SO TO SPEAK.
THE BRAIN SUBCONSCIOUSLY
RECALLS IMAGES
AND MATCHES THEM
TO A PHYSICAL
INSTANCE. OR AT ALL.

Continuing with research, Bachelard discusses interior and exterior spaces. In both series of drawings created, the interior and exterior of each drawing is shown.

Ironically, he says, “The two kinds of space, intimate space and exterior space, keep encouraging each other, as it were, in their growth.” (Bachelard). In this quote, it is revealed that the interior and exterior spaces work off of each other, coexisting. Curious, a few more graphics were created. The setting was a surrealist world, where the interior of the space, was the exterior.

If one were to go and view the home to deliver mail for example, they would see the living room instead of the front door and set the mail on the couch. This exercise was to celebrate the interior, and expose the intimate, personal nature the domestic space holds.

This was essential to the process, to realize the equal importance of the exterior and interior space. Though most of daily life occurs on the interior of a home, there is a relationship with the exterior that is only realized when the two spaces are viewed through a scope together simultaneously.

A house would not be one's home, without both spaces. One cannot exist without the other.

This solidified the importance of having both the interior and exterior remaining in the drawings simultaneously. Bachelard talks about poetry helping the person see, “Poets will help us to discover within ourselves such joy [...] of a perfectly familiar object, we experience an extension of our intimate space.” (Bachelard). Now, during the interviews conducted, no names or photos were ever shown. This was for the objective fact that everyone has a home, and these studies could be done with any domestic space. With this next series of drawings, it was time to mix the genres of drawings done so far and acknowledge the arbitrary person who inhabited the space.

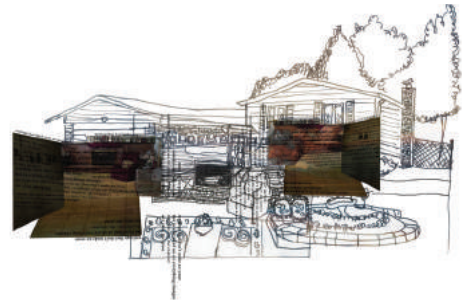
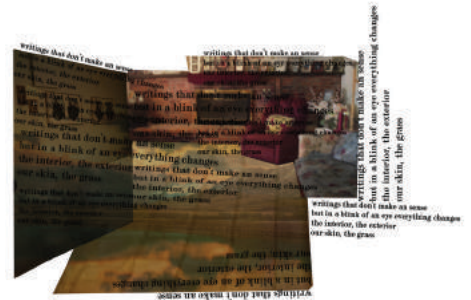







Writings that don't make any sense
What are these spaces
What are they trying to say



Do the walls speak to us or do we speak to them. Do we give life to the walls? Do we stimulate and understand them without the walls. What would the definition of life be?

Writings that don't make any sense

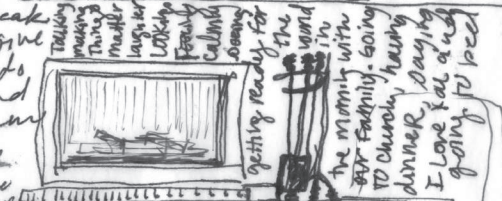

The way that some understand the way we see, communicate or interact. Is it the way the room is shaped the way we shape the space over time.

Are the photos on the wall what we are searching for to describe, or put meaning to? How do we represent these words?

There have been days in the bear film that have made me feel a certain way; uncertainly, helpfully, & want more to read

The scale of the familiar is important you need to realize what is what - what is Real, what isn't, is little memories or okay?

The things we think are the things that are both wrong and both right.

In order to change you must take the familiar away. make it look like another place. But in essence, it is the same place, with your same things. What do the things say? scale, of the familiar

Writings that don't make any sense

Writings that don't make any sense
but in a blink of an eye everything changes
the interior the exterior
our skin the grass

Writings that don't make any sense
but in a blink of an eye everything changes
the interior the exterior
our skin the grass

Since Bachelard had stated that poetry helps discover joy within ourselves with a familiar object, the new drawings were going to display a new language that was going to be more unfamiliar.

The drawings would be of the homes with the overlaid room, however, the home would start to unfold, and create new spaces within the home that overlap as well. In these areas that overlapped, there would be hand written thoughts, and poetry.

This overlapped area with the objects, and hand written poetry, would represent the center of the home. In a sense, the center of the home is you. The one who dwells, and inhabits the space, is the center. The center, is where the life is. Think about walking around in your house, and where ever one is present, and looks, that's what is being visually, and physically experienced. In essence, it could be the soul of the home.

“Vivid blue of a space

In which each tree rises to foliage of palms In search of its soul.” (Supervielle). The home contains meaning, from the human soul's energy. Without the soul, the house would no longer be a home. Imagine an empty shell. Imagine a living creature inhabiting the shell. Now, it's existence has meaning.

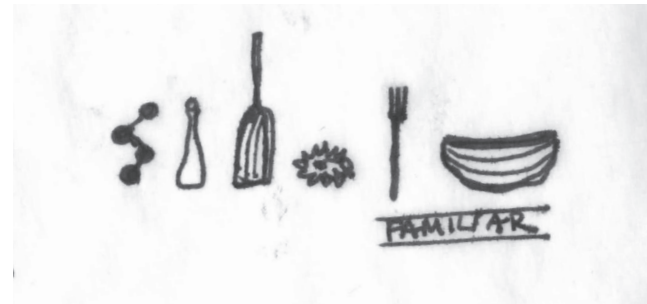

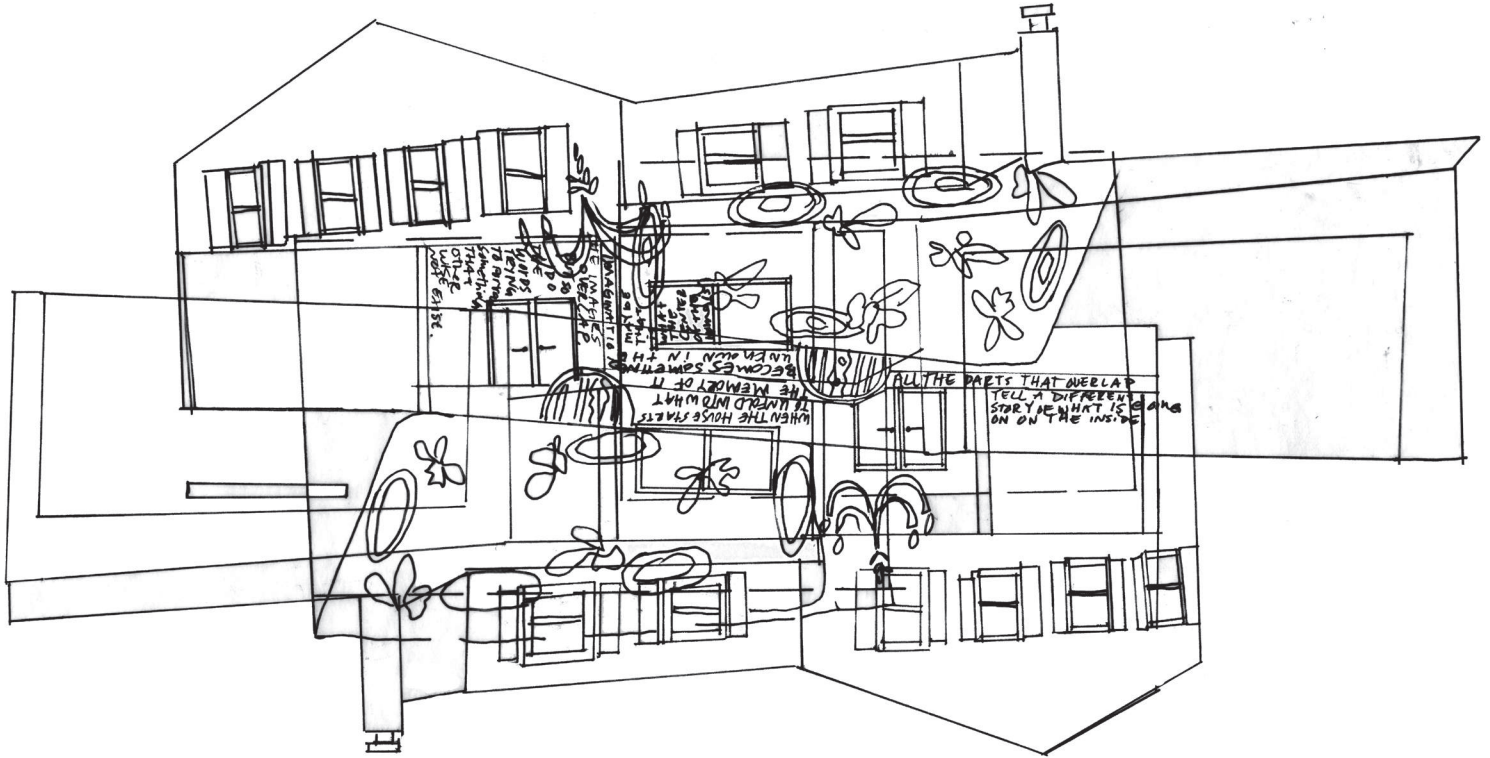

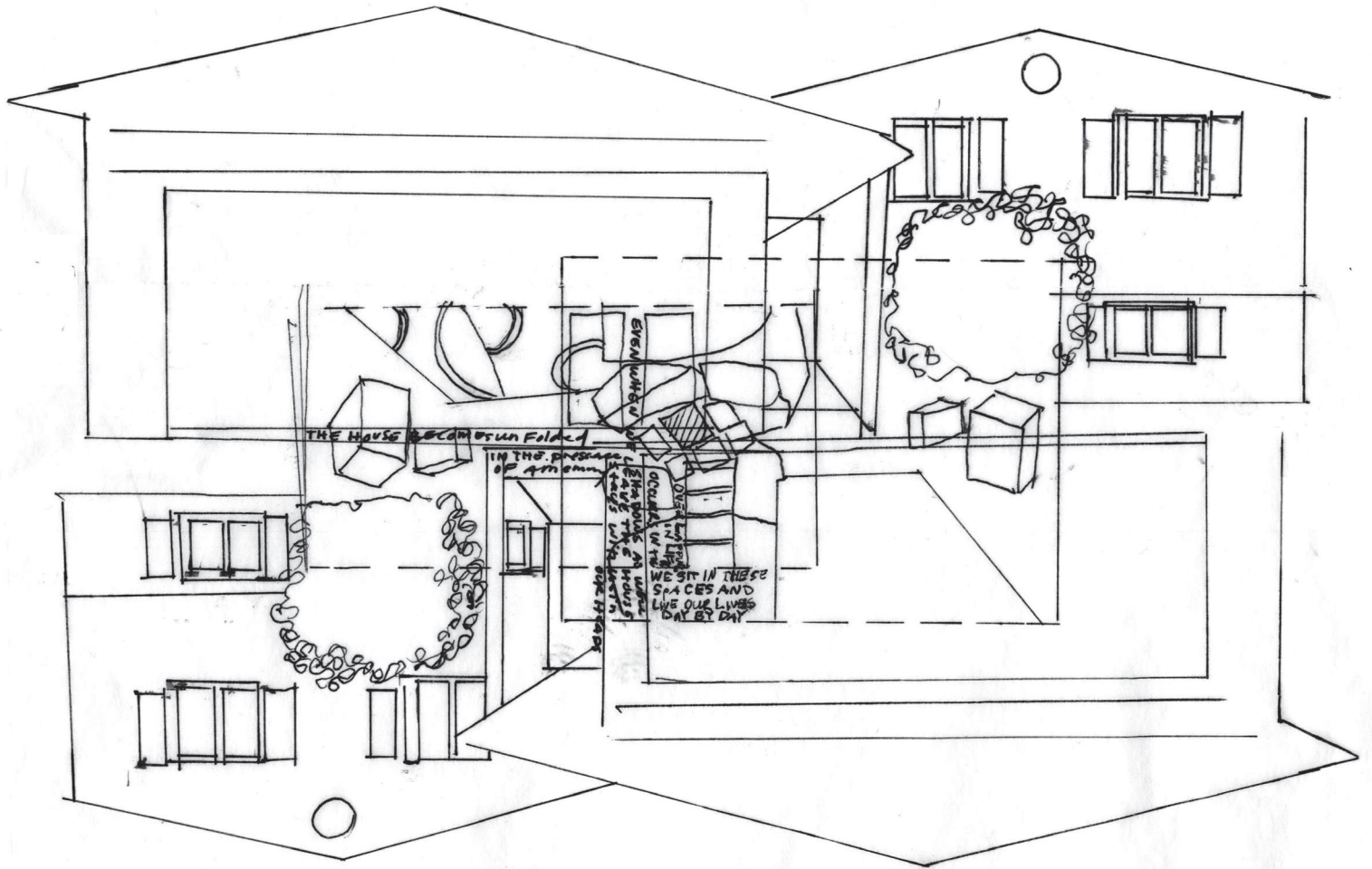

THE HOUSE BECOMES UNFOLDED

IN THE presence of 4mm

SITTING IN THESE SPACES...
WE SIT IN THESE SPACES AND LIVE OUR LIVES DAY BY DAY

WE SIT IN THESE SPACES AND LIVE OUR LIVES DAY BY DAY

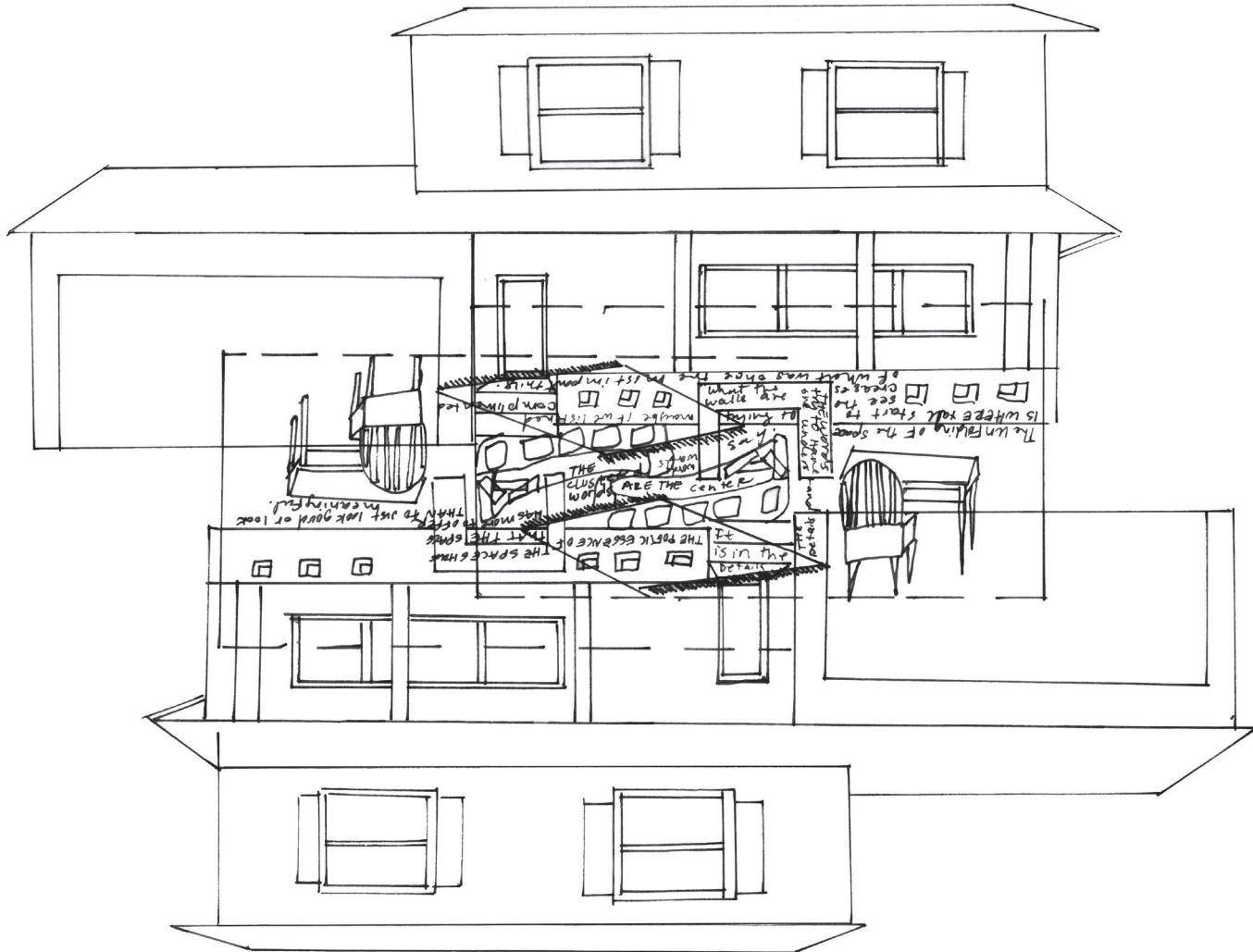

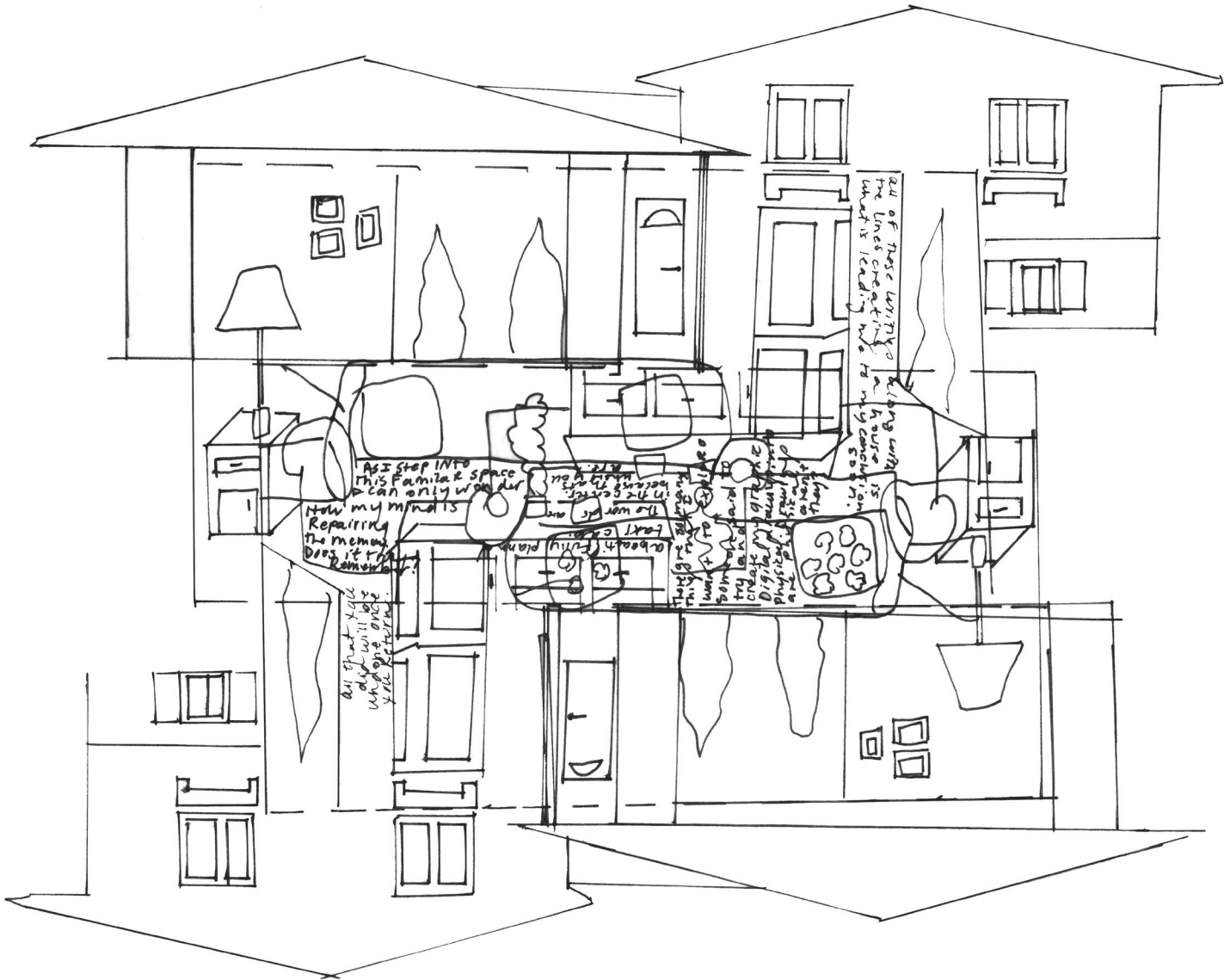

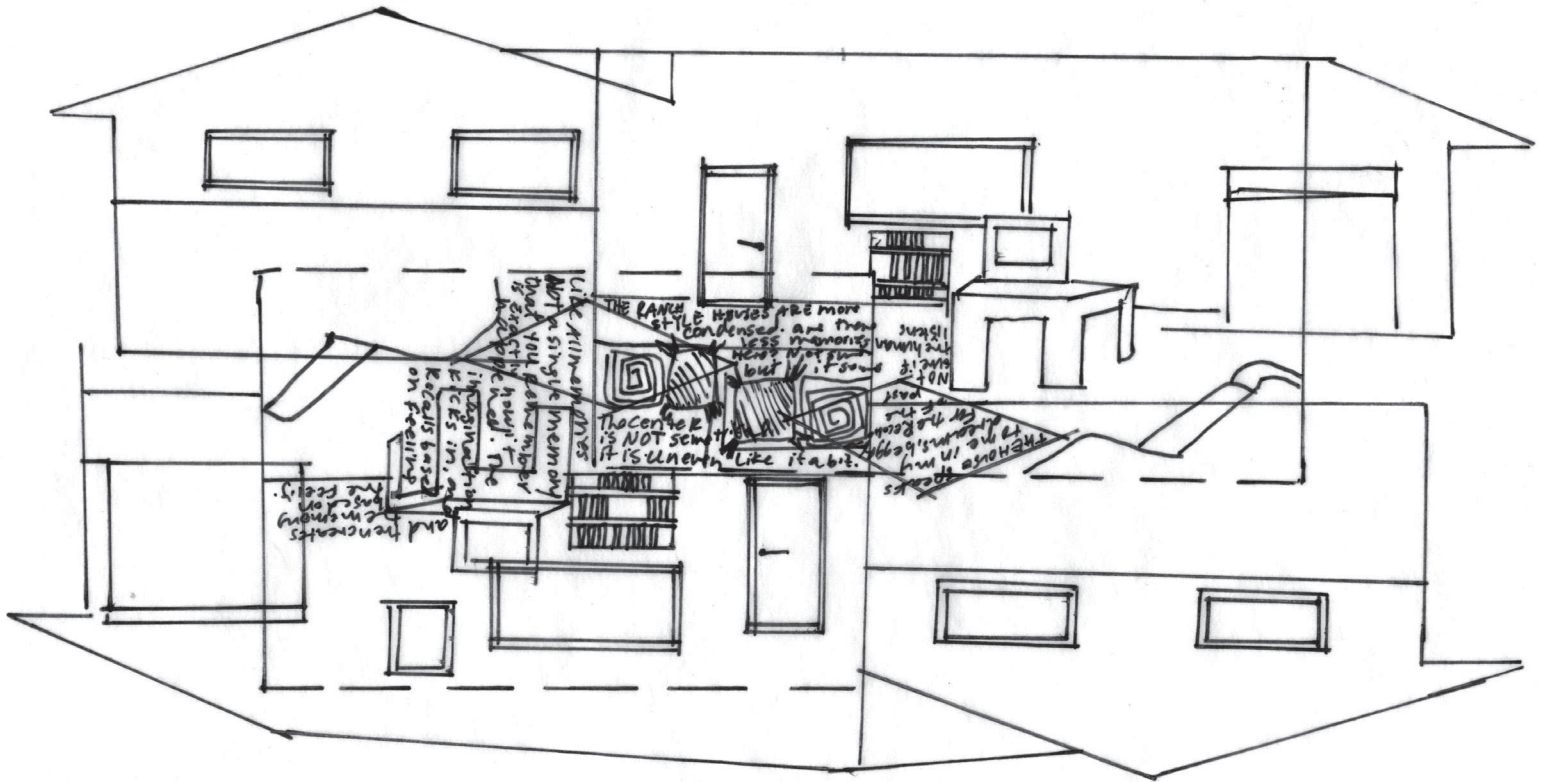

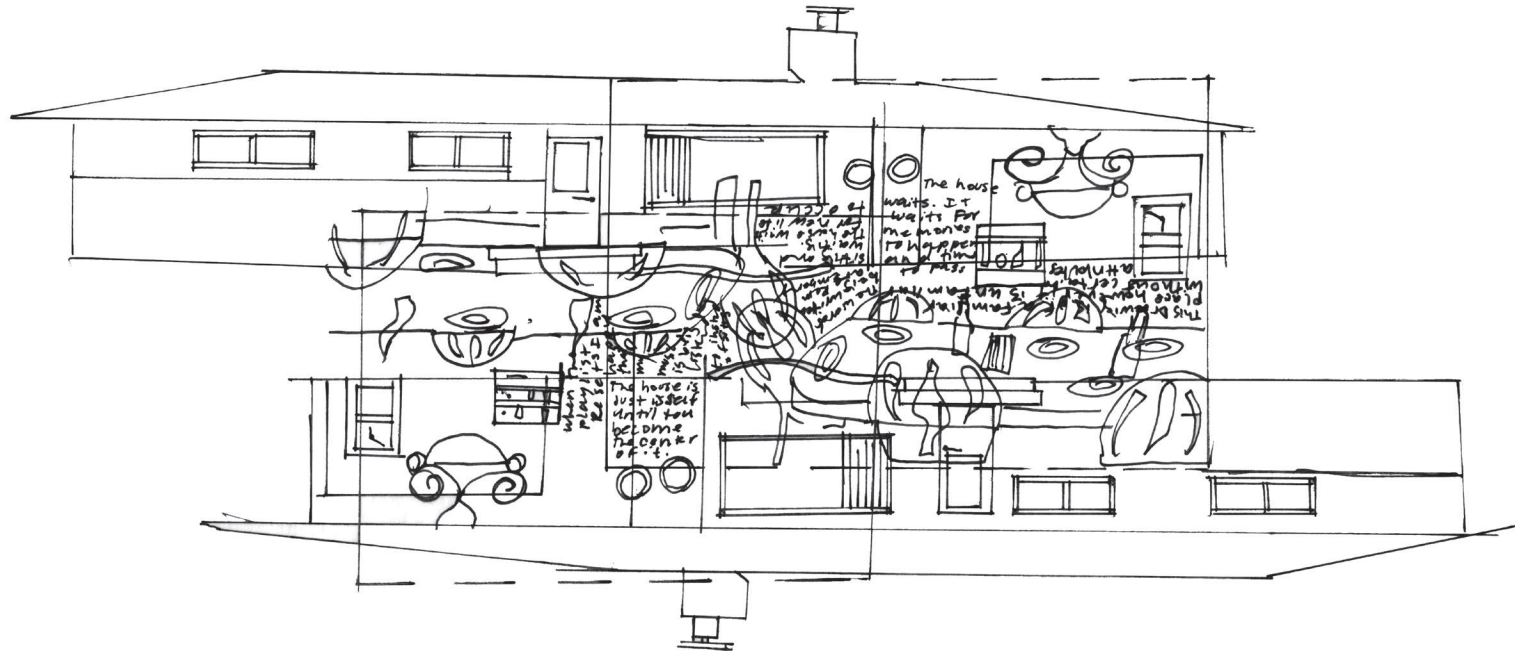

The concluding portion of this thesis was to take the defamiliarizing of the home even further. There was a series of six graphics of homes from the original interviews.

These graphics broke apart the domestic exterior of the home even further. As the home was shown shifting apart, there is a faceless person standing in front of each home. In essence, this was trying to send the message about what we are really designing for as architects and designers.

Is there a new way we are able to look at the home? This could be a message to consider the importance of people in the equation. Even though the thesis revolved around the domestic home, and the poetic essence of its existence, that poetic essence would never exist without a human life existing within the space.

To end, there is one last series of drawings representing the houses, and homes, being defamiliarized to its furthest extent of this thesis at the time being. It's a poetic, almost cubist approach on how to represent the domestic home, and what its true potential could be in the realm of life.







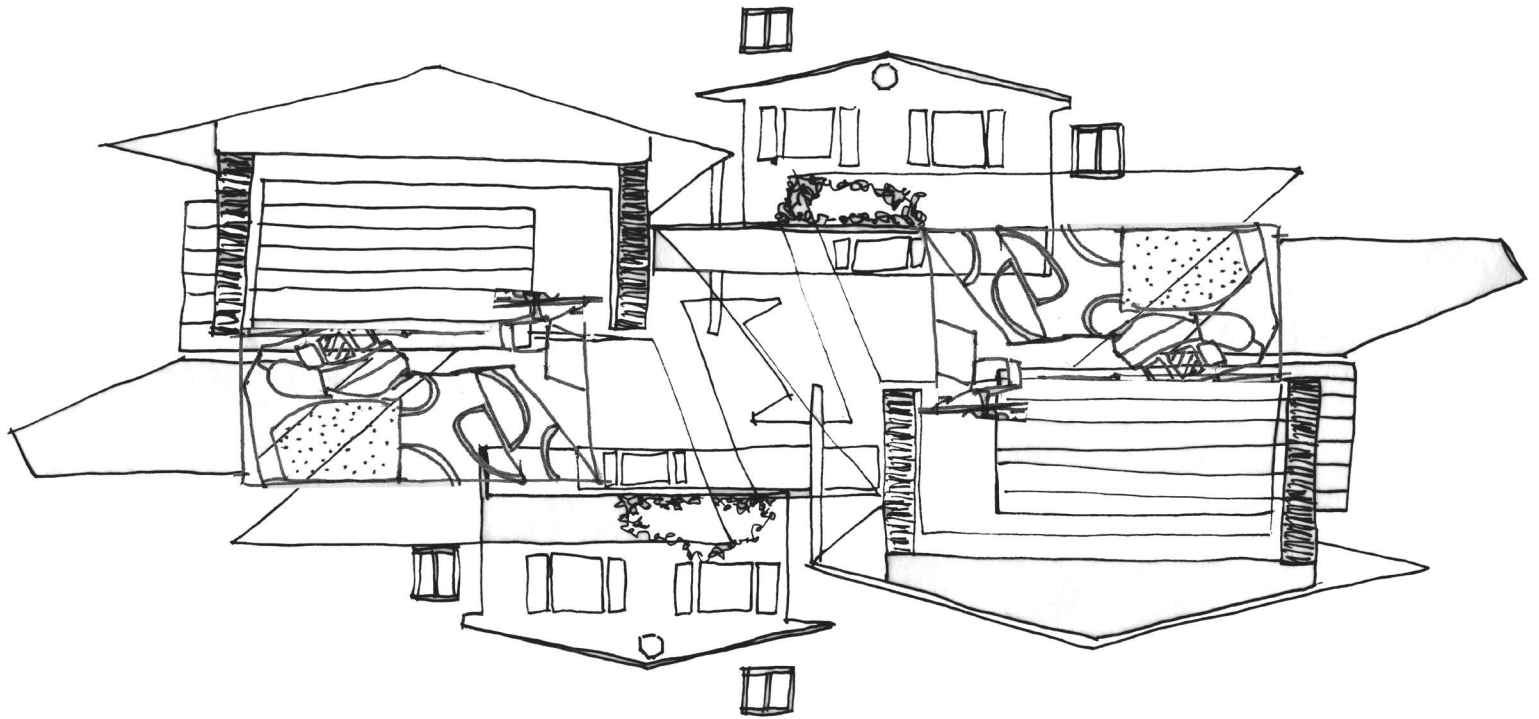

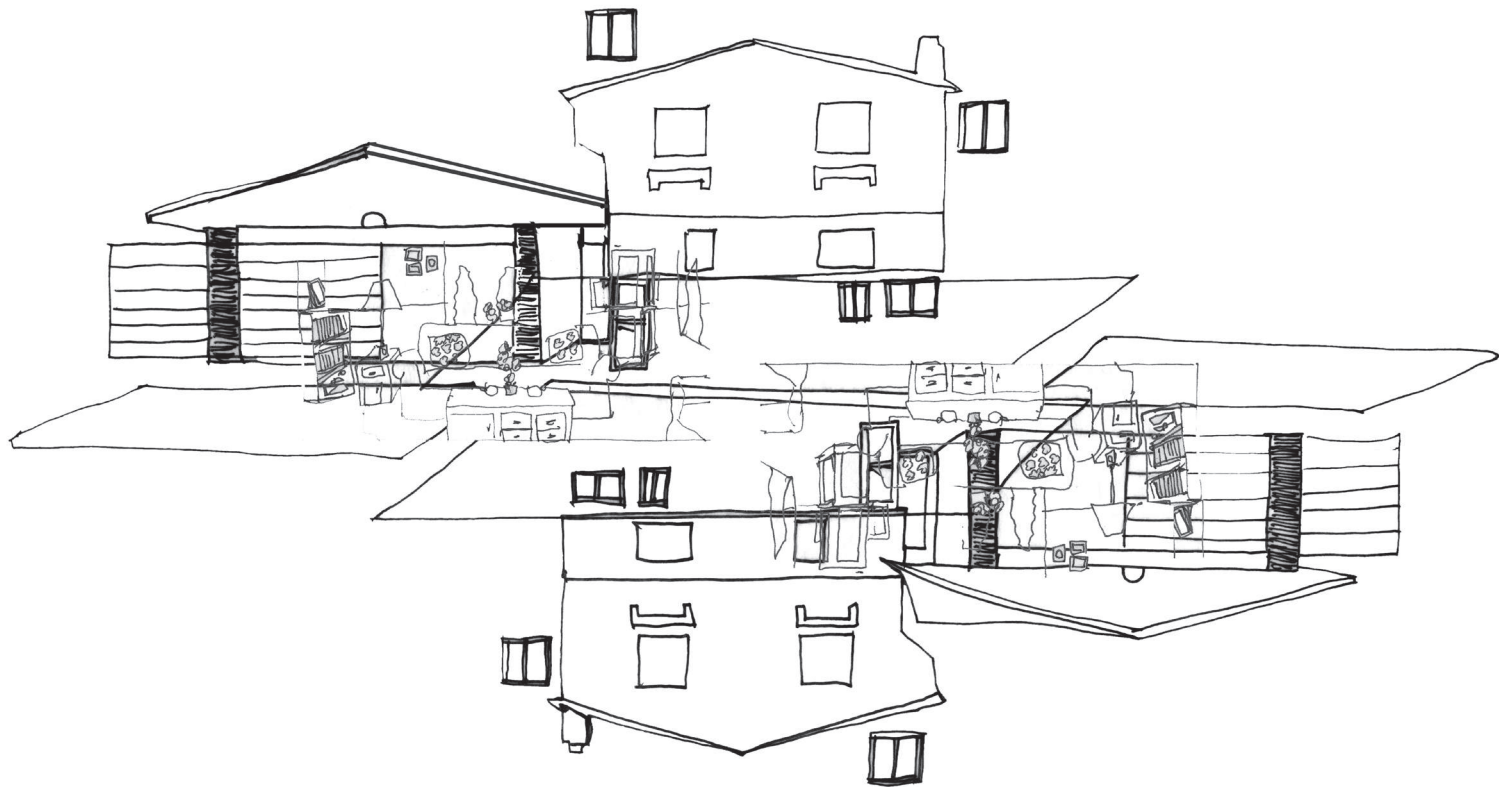

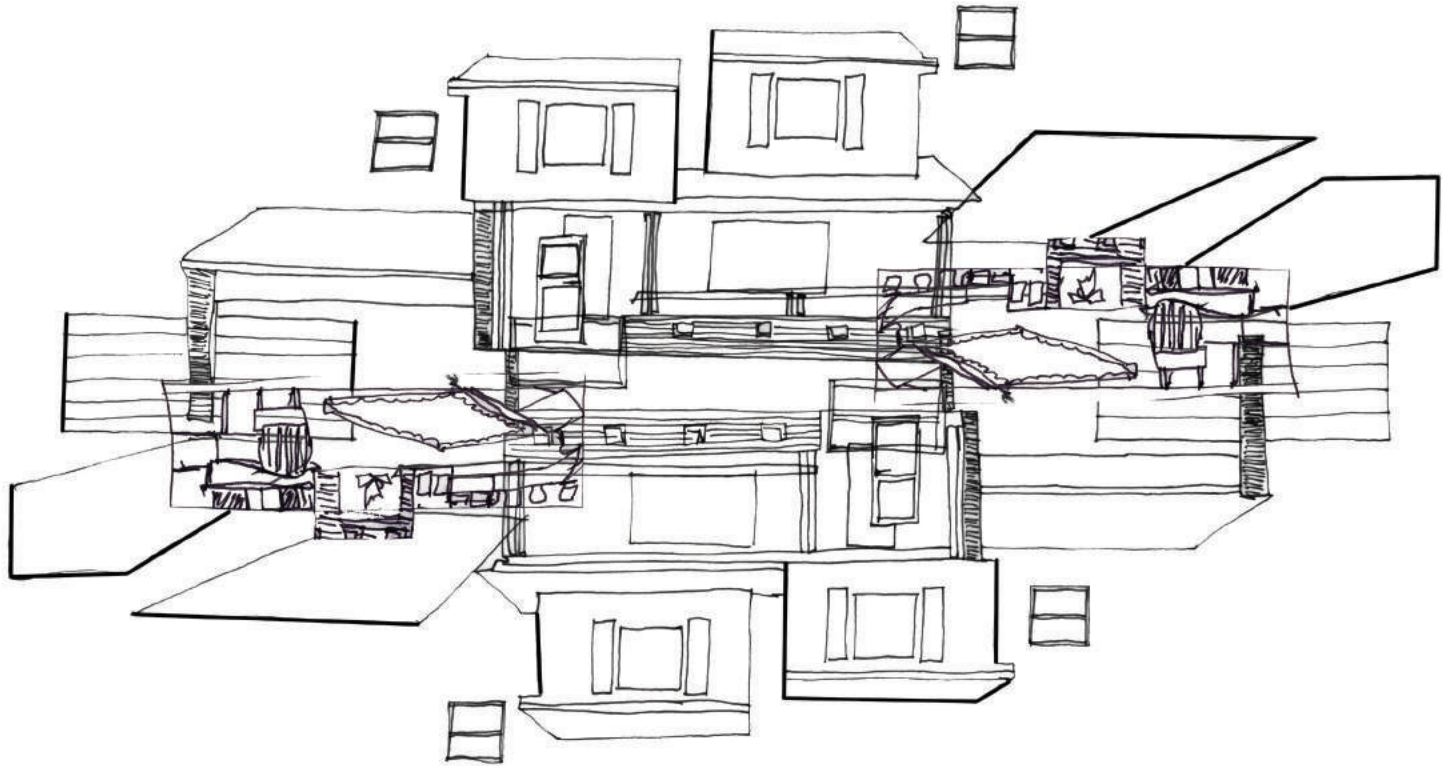



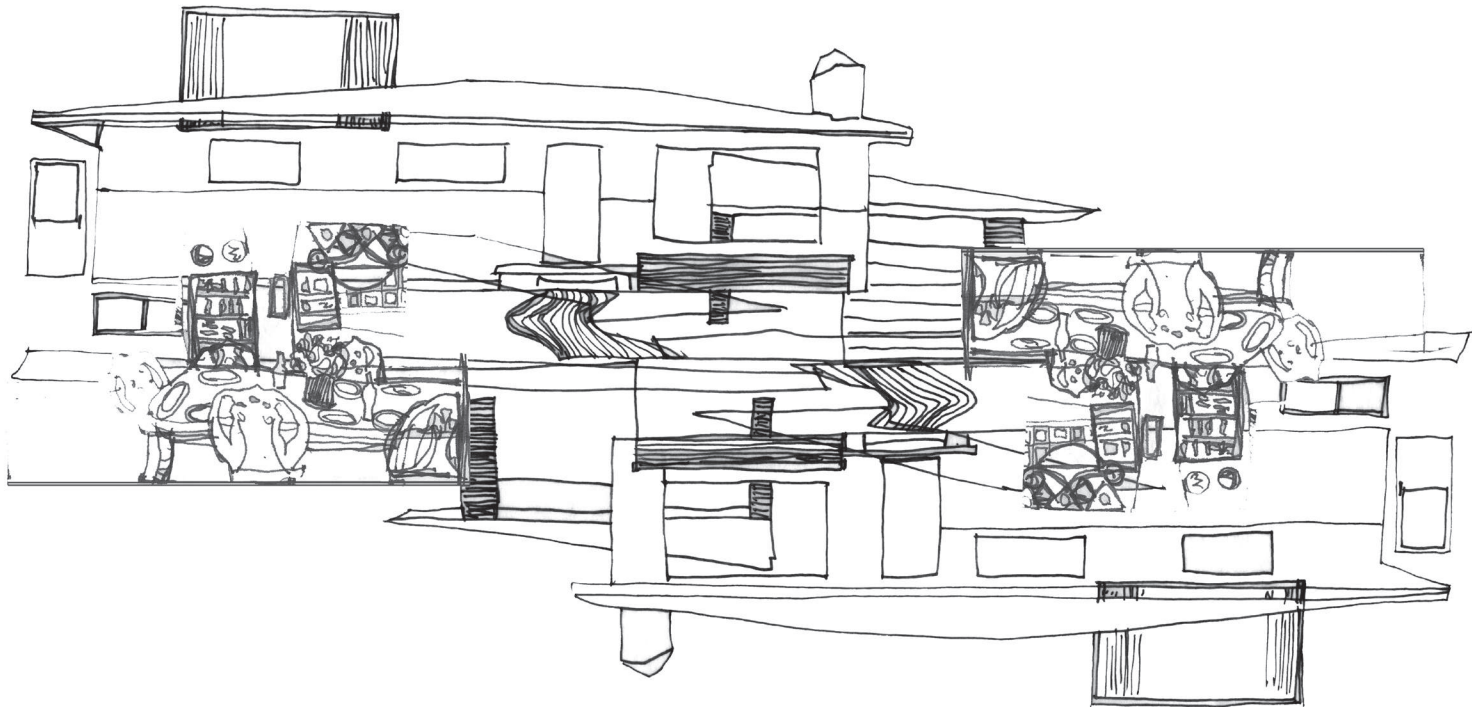

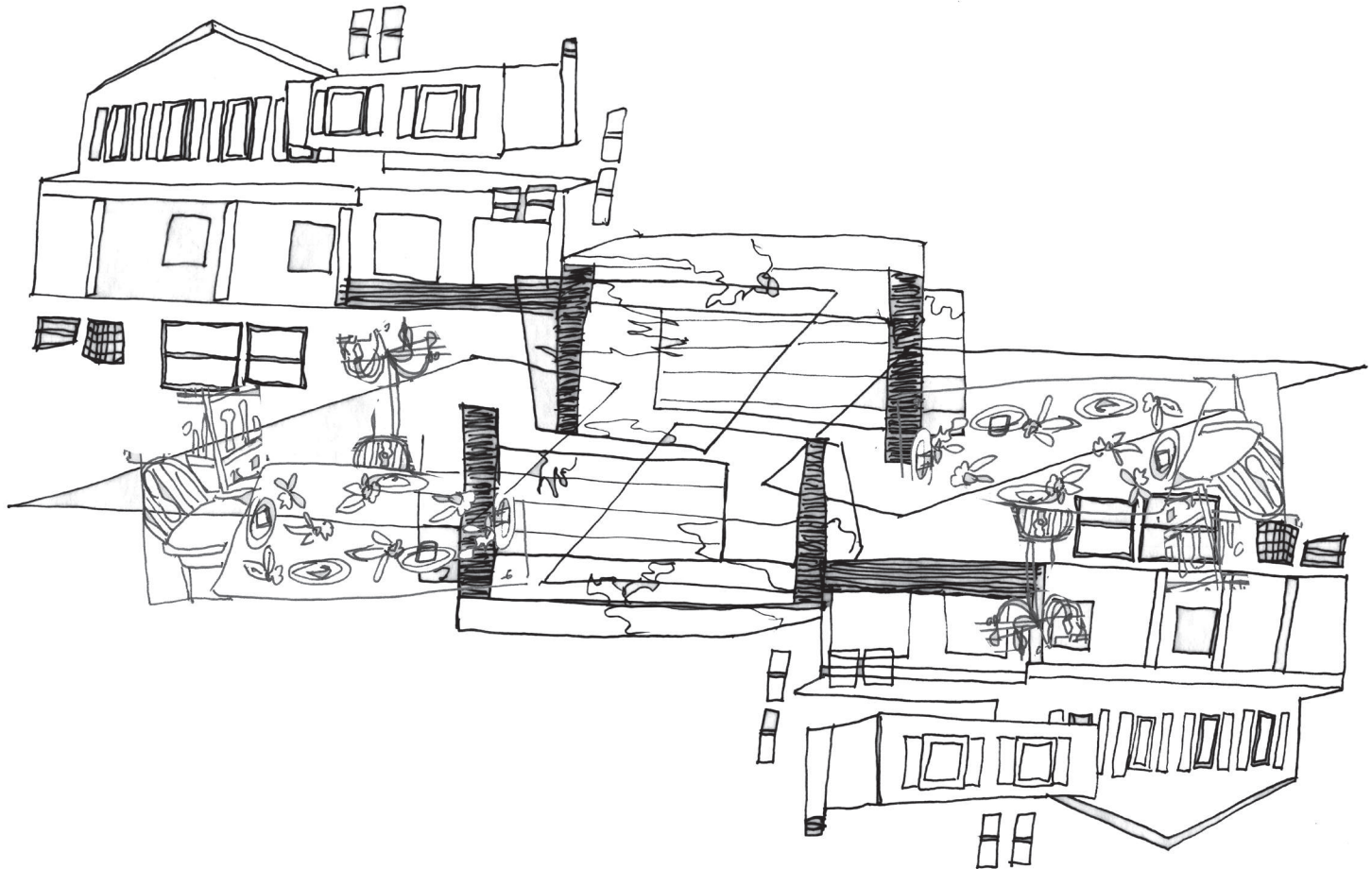

Personal Research

One other important experiment that was tried, was recording myself, and my thoughts about spaces. This was a study in a different medium in a sense. Maybe being raw with thoughts may trigger something unknown.

09_11_18

[00:00:03] “ I just went to my dad’s brother’s house, my uncle, he is my godfather and I went to go drop up a few garden supplies that he needed because he was cleaning the outside of their house. The trees he was trimming was really interesting. He was really excited about it, in the sense that he was being productive and taking care of the home. He was showing me how he sculpted the hedges and small trees. Once we start talking in depth about one thing, we usually continue on all avenues of thought which is really cool because him and I think really similarly. We ended up getting into talking about architecture a little bit. I asked him about my thesis very briefly and didn’t seem to want to talk much about it. But as soon as I mentioned something about up north he was more talkative and willing to give input. He cares about the cabin in a similar way to me and my parents do. So the initial topic of memory and home didn’t speak to him, but as soon as I mentioned a space he was familiar with, that meant something to him, he was ready to chat. It was really nice to talk about the cabin, and hear some memories he had from there. We continued talking about other subjects in general, such as the way people think and what things people are afraid of. And things about the existence of mankind of talking about how God is within everyone and everything is connected in the universe.

And I thought it was really interesting. I had mentioned to him that him and I both are completely comfortable with having casual deep intellectual conversation and we both smiled and chuckled about it. I found it interesting because I can automatically tell when I’m comfortable talking to someone who’s open to discussing those types of topics because they reciprocate the same feelings of enjoying depths of conversations like me. And when I was driving home I thought about the space we were in. I immediately wanted to take a picture of the outside of the house and a photo of grandma on the porch to record the memory.

[00:02:10] Grandma was sitting in the screened in porch and she was wearing a shirt that had a picture of my brother and I on it which was sweet. It was a really nice moment even if I was only there for not even a half hour. I started thinking about the idea I had about time invested in space, and it giving it more saturated memories. However I started to doubt that idea. It seemed as if I was there longer because it was deep and thoughtful conversation with both people but almost in a casual sense which is interesting. Maybe natural is a better term. I did continue to want to take a photograph to have the memory recorded of this day. But then I realized that from the photograph, a memory can’t record exactly what occurred in that instance, you can only look at it visually and the photo comes up with that direct physical image, so you will remember whatever your mind thinks about when it sees that image. So talking about it, and recording audio of the instance gives me a mental image now that I’m realizing more of what my memories are like. As I was driving home, I had some other random thoughts.

So today is my mom's fifty second birthday. It's 9 11 2018. my dog is 8 years old today ...and yeah. Then I started thinking about the space at my uncles house again. Back to the space where we were outside of the house and I can picture all of the four little tree hedges that my uncle trimmed and they look really good. I started imagining the instance without a picture. I told him they were a good sketch exercise actually. And there was another taller tree in the front which is near the covered porch with the truck. My mind started imagining the covered porch my grandmother was on, and it has a screen and a couple of chairs and a workbench. My uncle had just cleaned the porch so I could actually see all of the objects in sight. It looked open and pure. You could see all of the styles of furniture that created an atmosphere of comfortability.

[00:04:18] It's almost like all the pieces were vintage, or historical in a way. It made me feel something different, that I hadn't felt or noticed before. And especially my grandma being excited to be in that space made me want to remember it more. So maybe these spaces that we dwell in or our human existence is able to live in and feel comfortable and feel like we're in the right place. Maybe it deals with the atmosphere of the space and what items are like in the space. Why do they seem to fit perfectly in that space? Perhaps remembering something that was made of quality or material, made us think of a certain memory when we looked at the chair or the couch that my grandma was sitting on or the carpet and the texture and the color. Almost as if the man made-ness of these items were more intriguing

because they were older and you knew that people made these things with what they knew that they had. It was interesting seeing these things that you knew existed, and made you feel a certain way and they were not even yours. I didn't have any specific memory with them but I created that memory when I was there because of the way the items or furniture or anything was constructed because it was constructed a long time ago. The fact that you knew that people were genuine about hand constructing something and they didn't want to create it but had to create it gives it a different meaning entirely. Maybe They needed to make a profit. Perhaps once they created something, with their bare hands, that object then had some memory attached to it. And once that memory was attached to that object, the person never forgot about the work and effort they put into that object. Perhaps the object holds a significance, and that energy could be transferred to other people of the future if they take the time to study something, or give it meaning. Imagine the attachment to things that now we acquire in our own personal homes, and we can just sense the intrinsic value of the item. Well, I've cleared out my mind for the time being, but thinking in this manner about memory, architecture and objects, and what they hold or don't hold brought me here to this thought strain."

This first recording has some random parts in it in the beginning, but I believe it all stems from somewhere. Every part of an idea, has an origin of some kind. Through the process of the first recording, it started out about family.

The space was directly experienced by me, and my uncle. This type of thinking, or writing if you will, I like to call stream of consciousness. I was talking without really thinking about anything at all. Anything that came to my mind during that day I verbalized. I didn't realize some of the things I was saying until I reread it over again. There are some theoretical concepts that I talk about, but they don't necessarily directly connect to each other, but are still relevant to what I am trying to explore. Discussing experiences in a certain proximity, talking about familiarity of materials or objects and relating the space to the people who dwell there. At this point in my research I was taking two different instances of going about a problem, one graphically, and one experientially plus the audio experience after. There is one other recording from the same month when I was having a deep moment about memory, and wanted to document it.

09.13.18

[00:00:01] "I was thinking about memory and spaces again today and what types of things occur in my head to make me remember something about that instance or about a space specifically. I was really tired the other day and was laying on a couch with a knitted blanket on the couch. It was fall weather outside and it was cold in the basement. As I am recording this, it is pretty early in the morning maybe approximately 1:00a.m. or so. Some might consider it pretty late in the night as well, depends on your perception.

[00:00:47] I was thinking about the memory that was created in this space I was sitting in. It was foreign to me, because it wasn't my own home. Perhaps I starting thinking about these things because my significant other and I were watching a movie, and enjoying each others company. He went upstairs to go get something and I started to wonder why I was thinking about memory and space all of a sudden. Maybe it was the fact that it was just me dwelling in that space but fondly thinking about other spaces that I feel that I belong to. Could I have an attachment to that space just because I was experiencing it with someone I loved? Or was it the fact that I was in the space, regardless if it was a positive or negative experience I would have an emotion or feeling connected to the space if I was ever reminded of it in the future?

[00:01:15] I don't know if there is any specific criteria for understanding or knowing how an atmosphere makes you feel. But the fact that there's certain elements that humans pick up on in spaces whether it's smells textures or even, is curious, and in my opinion I feel like It must mean something, what is this type of thinking called? It cannot just be philosophy, or theoretical thinking. Is there some type of virtually that can be explained about memory in spaces.

[00:01:50] There are certain pieces of criteria that could dictate a space; the way that a space looks, what's in the space, things that you remember Perhaps you lived in that home for a very long time. Once you leave, do the memories leave with you? What if the moment that someone else moves

into that space, does it still have the same appeal that it did when it was yours? The nostalgic feelings of oh I used to live in this house and this was my room and you continue to find things that aren't the way you remember it. Does standing in that familiar room generate the memory? Does it really matter if you dwelled in a space for x amount of years, or is it washed away with a new face placing their belongings in it. Maybe it is different for every person. Maybe the room needs furniture, textures and items of this manner to recollect or generate these types of thoughts. I'm not sure what it is because I believe someone can feel nostalgic about an empty room. But I believe that you start developing a more or less attachment to it. There could possibly be levels.

[00:03:01] Physical or visual memory of a space exists, when there is a uniqueness about the space or the objects in the space. For example, like a chip in the door. It may have significance to you, but someone else who moves in could putty over it and think it's a flaw. When you look at it it's a physical thing but your mind is having this visual memory. If you just looked at any door that was manufactured that was the same. And you had no memory of it but it reminded you of something maybe that's more or less a different type of feeling and it's simply a feeling inside of a memory. So maybe you have to think about those types of things as well and take them into account. When it comes to memory and an architectural structure or a plain old building or a room you can study it. Chose something that you yourself can understand because it's a personal experience when it comes down to it in my opinion.

Empathy is a whole other thing where you can try to experience something through someone else's point of view. Like when you look at something that's from history imprinted in a building. Could you try to imagine like if you physically touched it or looked at it and studied the history behind it? Could you generate your own memories from that type of thing because it was created in a different time and space than you're currently in. That might be another thought."

This second recording questions a lot about physical and visual seeing. There might be some repetitive nature to it, but that is the beauty of it. The thought kept lingering. It was yearning for an answer. The over arching idea in this recording was curious about the relationship of the place, to the person or individual. Is it the person who gives the place meaning? Perhaps the life of the person transfers some sort of energy, and gives the house with its walls, and hallways, doors etc. meaning. It could be possible that any place that you live will have that residual memory, or energy forever lingering. The lingering energy could be connected to one's self and that could also be why memories stay with us like downloaded software on a computer.

Notes

-1/9/19

Realizing after reading part of the introduction, (and preface) the architectural uncanny this text has to do with the morbid, fearful side of the domestic/intimate space. Many of the words that are being used lead to anxiety, worry, fear of the unknown. They use examples of texts such as Edgar Allen Poe, to give an insight into the world of the “uncanny”. The Architectural Uncanny may be the antithesis of Poetics of space, but I believe I can connect the two. Without balance, a solution cannot be reached.

“the uncanny was, in this incarnation, a sensation best experienced in the privacy of the interior.”

The uncanny in this context discusses the fact that humans around architectural things, and being in society in general, is chaotic, and confusing; referring to Baudelaire wandering the streets of Paris trying to find his way in life, in society, in existence. I imagine Paris grey, while Baudelaire is wandering the streets as a flaneur. Vidler states the uncanny usually occurs in the privacy of the interior. Interior spaces, interior thoughts etc.

Maybe, the uncanny represents the existential thought of being in a space, existing in a space without knowing why you think in the first place.

“ being, as cold air sneaks through poorly insulated sill, cutting through skin, sending chills down one’s spine. Evoking worry, of being cold cold, and blue”.

1/11/19

The endless quest of detective clues through the apparent chaos of urban life....

This sentence has many things packed into it. The clues they speak of, come from the curiosity of humans. about life within themselves. They may try to go searching for answers,, and find certain things during their journey that may give ideas as to why they exist, or whatever question they may have, but it is inevitable for them to realize that there is truly no end to the search. They may come close, but the reality of urban life during the day, during the night, is what it is.

I’ve had a thought about chaos. Does chaos truly exist? Or do humans on earth create the chaos themselves. Is it a mental chaos, inside one’s head, that overwhelms and boils over, reflecting onto life, exteriorly? Everything in nature seems to mind its own, and never worries. Humans have inherent questioning, worry, and anxiety. The rest of the world, nature and animals, seem to just exist, and trust in the life they were given (in a sense).

The word endless talks to me. It tells me that there is this potential of something, but the potential will infinitely exist, no matter what problems are solved, how much time it takes to achieve a goal, it’s the roundness theory that Bachelard discusses.

Personally I could even picture, when I am overwhelmed at the potential I have as a human, it becomes this “spinning” thought is what I usually refer to it as.

-Alienation of the individual - Rousseau
- Baudelaire

- Baudelaire

-Instead of the intimate space being a beautiful discovery of self with poetic evidence, or are intimate spaces the key to the underlying dark uncanny of existence?

-Isolation from nature with the built environment?

-Is a home permanent or will one always feel somewhat out of place because of the past they did not experience in the space?

-Argument that the natural environment would be a better dwelling space for a human as it is for a fish; connected to their surrounding, easing the mind; unable to live comfortably in the world in man made isolation.

The chaos of life, is always going to exist, however, intimate space is the balance, and will also be just as important. Having something that you know, countered with something you do not know.

“rushing every morning, continuing this phenomenon, called routine

Unsure of the first name, or even the last, as soon as the sun starts setting, and I start my car, the chaos for the day, is seemingly so far. theres no where else in the world I feel that I belong.”

Where there is chaos, is there no calm until we reach our private abode?

01/14/19

Talking with others, I realized my new found organization method isn't perfect. The fact I started talking about chaos, is interesting but it shouldn't be the main idea of what I want to find in my thesis. At this point, I was unsure of what I wanted my end goal to be. I knew I wanted to dive more into intimate space, and how it balances social life for humans.

“Belonging, Wanting, Receiving.

could we belong to something and nothing all at once or belong to nothing and something not at all is that space we think of truly ours or does it move”

01/16/19

Today I realized that my semester should be an evolution of my findings from last semester. I was concerned I wasn't sure what my project was going to become. Perhaps I should evolve my graphics and writings, into video and spoken word?

Evolve from Memory, to spaces, to poetry. Materializing something from a mental thought to something tangible.

-Ideas for moving forward;

interviews about poems

case studies about specific intimate spaces

time-laps video of daily routine

the association of ideas theory

clear idea or definition of intimate space

section model hiding intimate spaces

familiarity of spaces

“afraid of not understanding
afraid of the unknown to come; is it here already, or has it
always been
afraid by the lights turned off; what are you afraid of?
afraid of being uncomfortably out of place
afraid of what I know becoming a stranger, these walls, those
floors
the creak of the back door or the squeak of the front, the soft
scuff of feet walking on
the carpet, the shift of the boards
the silence of the personal paradise, to wonder if it is truly
wonderful”

- no video?
possibly instead having words that become the image

01/18/19

Maybe, poetry is what a space is filled with. In a virtual realm, the space is filled with words. Words, thoughts, conversations. Maybe it is the spaces job to be a container for the words. Perhaps the space speaks through the things that you place in it to make it personal, to make it intimate. Every piece, color, object, texture gives life to a space, they represent the words that are not being said. Unspoken questions and conversations that are waiting to be heard about. The virtual conversations that occur in each of our minds has an individual quality that is celebrated with the physicalness of the world; the physicalness of each thing in a room. The words are in the details. However it takes a human to uncover these hidden unspoken words.

For example, taking a drawing of a place that one already know exists, and keeping it unfinished, for the sheer fact that in one’s mind it is unfinished- that is how the world should see it. You are the only one who can know the space, and uncover those hidden memories, images, words, conversations. This topic is still objective of the fact that every person who has ever lived anywhere, has this quality to. Only intimate space has as strong or dense of a conversational memory in it. So this said drawing has only certain parts of it drawn, and the rest is filled with physical words, and phrases, poems , etc. This may be something that I didn’t realize was real in the first place.

There is a physicalness to space
There is a virtualness to space.
“once uncovered, can never be re-covered.”

01/29/19

Found many things out that I wasn’t expecting but happy that I ended up realizing. The one resource the architectural uncanny, is not a valid resource for my research and project. However, it is a great counter argument for the negative side of intimate spaces. Now that I have written about that aspect it helps further the other ideas that I currently am working on. I’ve decided to focus on the chapter of intimate immensity in Bachelards book, poetics of space. I focused on some other theories last semester, but I believe that this chapter will benefit me most in what I want my project to come out to be in the end. Well, “end”. This project may be an on going occurrence forever, but I want to come up with an end result for this semester.

Another thing I failed to mention was about the graphics I have been working on. I started taking major parts of the interior photos that I collected from my interviews last semester, and basically making the interior of a space, the exterior; It looks like some surreal image, but it needs to be this way so my point is clearly taken by the jury and others.
02/01/19

Thinking of the exploded diagram of a room; this adding onto the model I had in mind. If the rooms graphically have this three dimensional quality, then the model can be the next step in the process.

Words. The word/house drawing that I was thinking of. Possibly, I can start creating an exploded diagram of those rooms, and add in words that make up part of the drawing?

02/08/19

Creating rooms that are stitched together by words. Assuming the words are something that are always embedded in the space in a phenomenological sense? or in a virtual sense? Could these words possibly be energy stored in the areas? Or, could the words be the physical form of the memories in the spaces we experience.

What am I trying to say about Intimate space? Am I trying to show the importance of Intimate space in the architectural realm? or just in life? This idea of how humans interact in spaces- are intimate spaces the “ultimate” space for humans to be their genuine self? Why does it matter that a human is its genuine self? Am I insinuating that architecture controls how a human interacts with it based on the social impact?

In the theory of Intimate Immensity, intimate space is imperative for human growth.

“The purpose of a home is to understand ones inner self through self reflection, and personal intimate memory/ experience. Once achieved, one is able to step out into the inner most intimate space and expand the innate thoughts onto the exterior world to start understanding a new type of self awareness with all spaces that exist. Intimate self inner awareness automatically grows stronger when the intimate relationship with ones self is achieved and it breaks out of personal intimate space, then all or more spaces start to become intimate as well. Inner Immensity is a result of immensity which is always inner. real meaning to ___ expressions concerning the visible world.”

- Immensity- enormous size, scale or extent of something

The graphics becoming once piece of a whole. The presentation becoming a narrative or a story. Not a normal presentation. Starting off with my ideas, my curious thoughts, and turning it into something that everyone would be able to connect to. Talking about things that are maybe more or less tough to discuss, or even comprehend. Leave the audience in awe.

Maybe even start to write a short story about what I have learned throughout the process of my entire project.

03/11/19

Realizing I haven't written in a long time in this journal of the semester. Which is not good, since the final is due at the end of the month. Perhaps I should start to widen the research a bit, to get another epiphany about my research.

Possibly writing more poetry, doing more iterations of drawings; revisiting my extractions, and hand drawing some of them, creating some new extractions and drawing those?

03/15/19

The other day, reading more of the chapter house and universe,;

“to give unreality to an image attached to a strong reality is in the spirit of poetry”

“thus an immense cosmic house is a potential of every dream of houses”

“it is a strange situation. the space we love is unwilling to remain permanently enclosed. it deploys and appears to move elsewhere without difficulty; into other times and on different planes of dream and memory.”

“a house that stands in my heart my cathedral of silence every morning recaptured in dream every evening abandoned a house covered with dawn open to the winds of my youth”

I thought; imagination and the wind dictating the passage of time

there is personification of the house- need to represent

“houses that were lost forever continue to live on in us; that they insist in us in order to live again”

I thought;

“the amount of imagination,

the amount of dreaming, the amount of thought and time in one space

creates a house in your mind that is part of the unreality that will forever be infinite”

These thoughts also continue onto separating thoughts of the house; the mind starts to remember only bits and pieces of the house you once knew. If your proximity to the house is no longer there, the reality of the house is not there either. The imagination starts to run wild and pull out the essence of a feeling, of a physical thing. Somewhere you once called HOME. The memory of the intimate space doesn't exist without it's center. The center, is you. Wherever you are, that is where the center will be.

-Journals from the thesis process-

Referenced quotes from Poetics of space, and other writings by Angela Hampel

